



GX Series

Standard Water Gas Fired Exchanger Humidifier

SHEET NO.

GX-1



Looking for an alternative to electrically generated steam humidification? Concerned about using chemically treated boiler steam for direct humidification? If so, PURE's "GX" Series (patent no. 6,705,535) Gas Fired Humidifiers are exactly what you're looking for.

The "GX" Series Humidifiers utilize a stainless-steel heat exchanger, which allows for a gas power burner to be used as the energy source for producing steam from tap water. The steam produced by the "GX" Series Humidifier is free from chemical or mineral carryover, providing pure humidification for today's stringent indoor air quality requirements. PURE's highly efficient heat exchanger produces combustion efficiencies up to 84%, as well as providing simplified maintenance.

Each humidifier is supplied with an INTAC® control system mounted in a NEMA-12 enclosure. The INTAC® microprocessor control system provides constant monitoring of the water level and safety systems, as well as providing a gas valve interlock. This will prevent operation should any of the safety circuits open.

The "GX" humidifiers come standard with free-standing support legs, factory mounted control panel, factory insulation and DCT-927 drain tempering kit. Multiple injection tubes are available for improved dissipation of the steam in large ducts or manufactured air handling systems. Multiple humidifiers can be manifolded together to a single injection tube system to provide increased capacity on large air volume projects.

The versatility of the "GX" Series will allow you to design them into any system simply, efficiently and reliably.

Our results are comforting



Capacities, Electrical & Weights

GX Series

SHEET NO.

GX-2

This humidifier is a forced combustion type that can be used with natural gas or liquid propane. The burner can be easily removed to access the side entry exchanger(s) for cleaning. It is designed to work with low-pressure gas between 5" W.C. up to 14" W.C.

Unit Capacities in Pounds per Hour (Kg/Hr) † Weights in lbs (kg) and Electrical Specification

Standard Water Unit Model No.	Steam Capacity lbs/hr (kg/hr)	No. of Burners	*BTU Input	#Exhaust Manifold Vent Size (cm)	Shipping Weight	Operating Weight (kg)	120 Volt, 60 Hz
							Full Load Amps
GX-3	110 (49.9)	1	150,000	4" (10.2)	201 lbs (91.2)	420 lbs (190.5)	5.0
GX-4	300 (136.1)	1	400,000	4" (10.2)	390 lbs (176.9)	710 lbs (322.1)	5.0
GX-8	600 (272.2)	2	800,000	6" (15.2)	827 lbs (375.1)	1391 lbs (630.9)	10.0
GX-12	900 (408.2)	3	1,200,000	8" (20.3)	1125 lbs (510.3)	2072 lbs (939.9)	15.0

† Actual humidifier capacity may vary due to the heat loss from the humidifier reservoir. The ambient air temperature, air velocity and injection tube system will affect the rate of heat loss from the reservoir.

* Altitude adjustment:

100% up to 2000'

Over 2000', 4% de-rate per 1000'

Vent Size is larger than connection size.

Gas Piping Pressure Drop Data

EQUIVALENT LENGTH OF STRAIGHT PIPE IN FEET									
	20	30	40	50	60	80	100	150	200
CFH GAS WITH .2" PRESSURE DROP									
Pipe Size in Inches									
3/4"	152	120	105	93	84	73	66	54	45
1"	300	250	210	190	180	150	135	110	75
1 1/4"	520	425	360	325	300	260	230	190	165
1 1/2"	800	690	560	500	480	410	370	300	260
2"	1700	1400	1200	1100	1000	850	750	600	540
2 1/2"	3000	2500	2100	1900	1800	1550	1375	1100	950
EQUIVALENT LENGTHS OF STANDARD PIPE IN FEET FOR LISTED FITTINGS									
Fitting Type	3/4	1	1 1/4	1 1/2	2	2 1/2	Nominal Pipe Size in Inches		
Std. Tee	2.4	5.5	7.5	9	12	13.5			
Std. Elbow	4.4	2.7	3.7	4.5	5.5	6.1			

Gas Input CFH for GXDDR Series Humidifiers

Model No.	Max BTU/Hr Input	Max CFH (Nat. Gas)	Max CFH (Propane)
GX-3	150,000	150	60
GX-4	400,000	400	160
GX-8	800,000	800	320
GX-12	1,200,000	1200	480



GX-3 & GX-4 Dimensions

SHEET NO.

GX Series

GX-3

Required Clearance:

For recommended service and maintenance purposes the following clearances should be maintained:

Right side, see Top View for required clearance

Front side, NEC requires 36" clearance to control cabinet

Left side, 6" for access

Rear, 6" for access

Top, 12" for cover and Tri-Probe removal

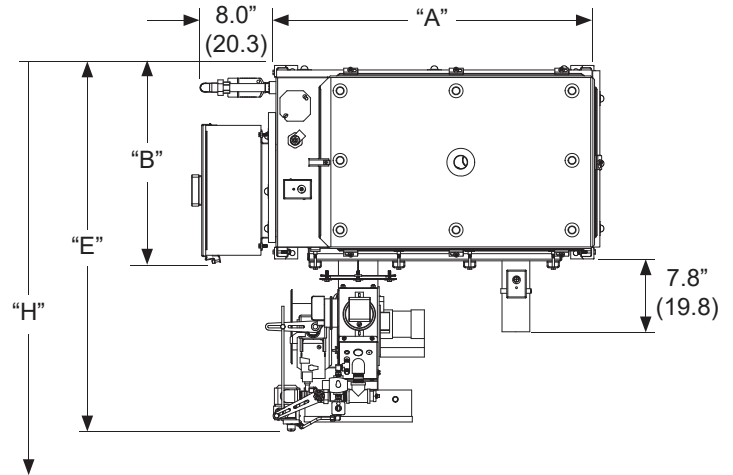

Clearance required for exchanger removal

Top View

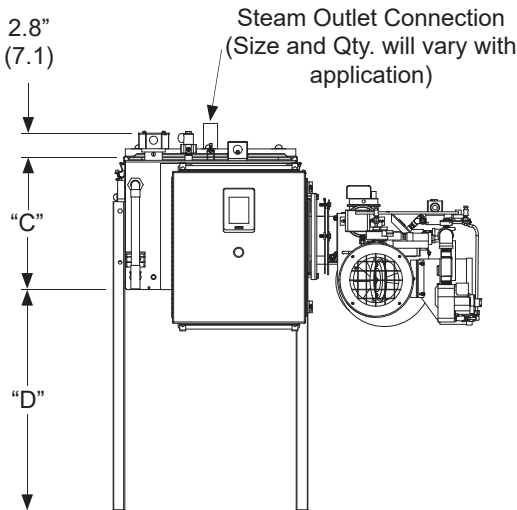

Front View

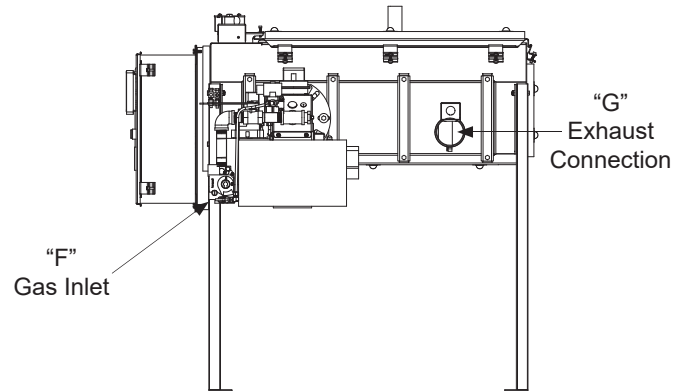

Right Side View

Unit Dimensions in Inches (cm)

Standard Water Unit Model No.	Dim. "A"	Dim. "B"	Dim. "C"	Dim. "D"	Dim. "E"	Dim. "F"	Dim. "G"	Dim. "H"
GX-3	34.18" (86.8)	20.46" (52.0)	13.84" (35.2)	24.0" (60.9)	45.9" (116.5)	3/4"-NPT	3.0" (7.62)	50.0" (127.0)
GX-4	54.0" (137.2)	30.1" (76.5)	13.84" (35.2)	24.0" (60.9)	54.7" (138.9)	3/4"-NPT	3.0" (7.62)	66" (167.6)

Heat exchangers have a top and bottom. There is a break (crease) on the bottom side of the heat exchanger. Do not install heat exchanger upside-down.

All dimensions are approximate and subject to change at manufacturer's discretion.



GX-8 Dimensions

GX Series

SHEET NO.

GX-4

Required Clearance:

For recommended service and maintenance purposes the following clearances should be maintained:

Right side, see Top View for required clearance

Front side, NEC requires 36" clearance to control cabinet

Left side, 6" for access

Rear, 6" for access

Top, 12" for cover and Tri-Probe removal

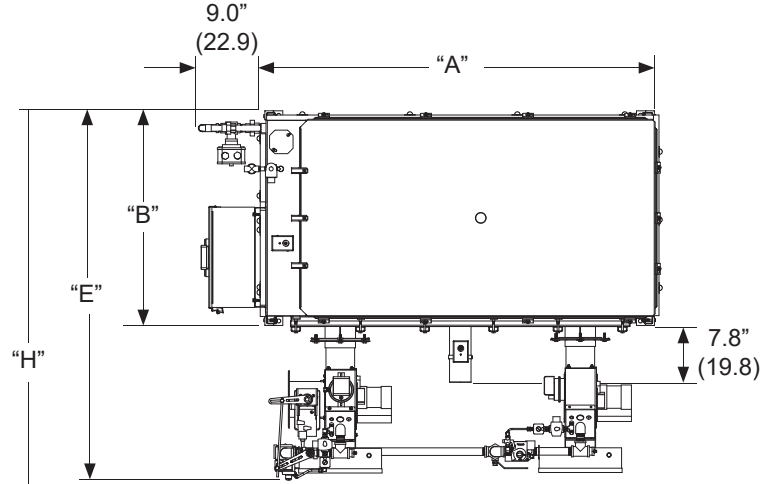

Clearance required for exchanger removal

Top View

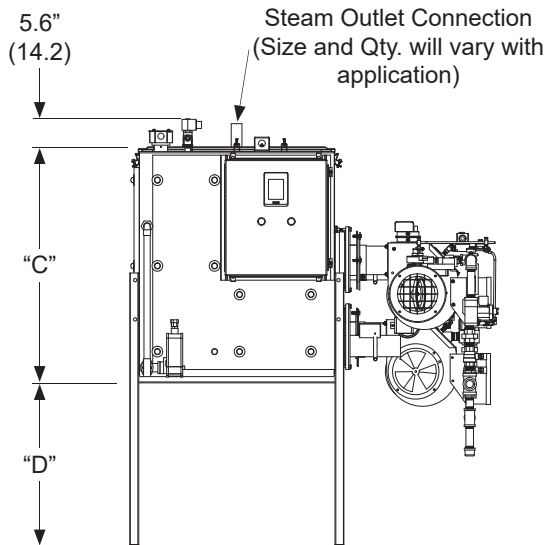

Front View

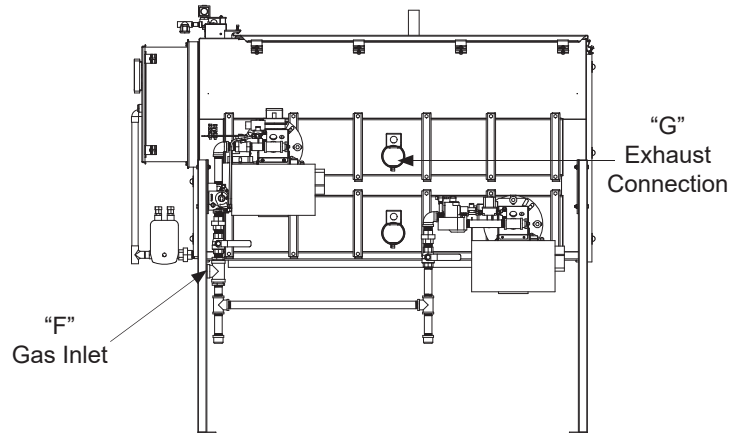

Right Side View

Unit Dimensions in Inches (cm)

Standard Water Unit Model No.	Dim. "A"	Dim. "B"	Dim. "C"	Dim. "D"	Dim. "E"	Dim. "F"	Dim. "G"	Dim. "H"
GX-8	54.0" (137.2)	30.1" (76.5)	32.5" (82.6)	24.0" (60.9)	54.7" (138.9)	1"-NPT	3.0" (7.6)	66.0" (167.6)

Heat exchangers have a top and bottom. There is a break (crease) on the bottom side of the heat exchanger. Do not install heat exchanger upside-down.

All dimensions are approximate and subject to change at manufacturer's discretion.



GX-12 Dimensions

GX Series

SHEET NO.

GX-5

Required Clearance:

For recommended service and maintenance purposes the following clearances should be maintained:

Right side, see Top View for required clearance

Front side, NEC requires 36" clearance to control cabinet

Left side, 6" for access

Rear, 6" for access

Top, 12" for cover and Tri-Probe removal

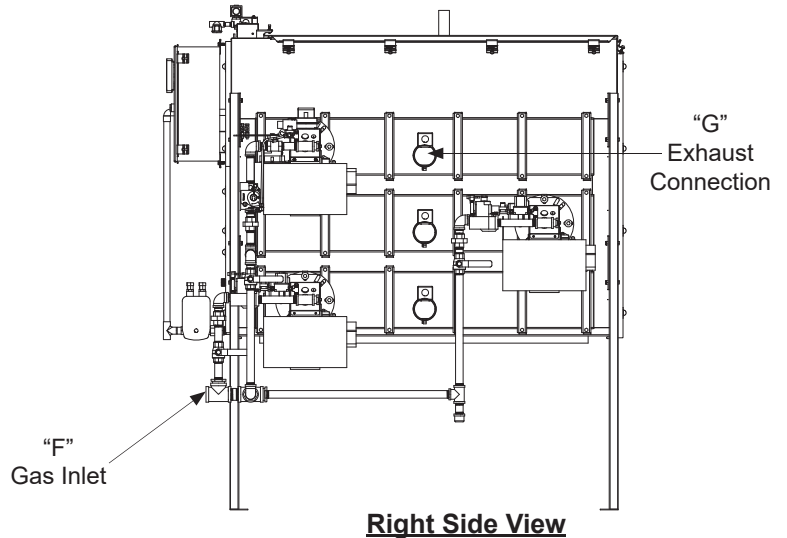
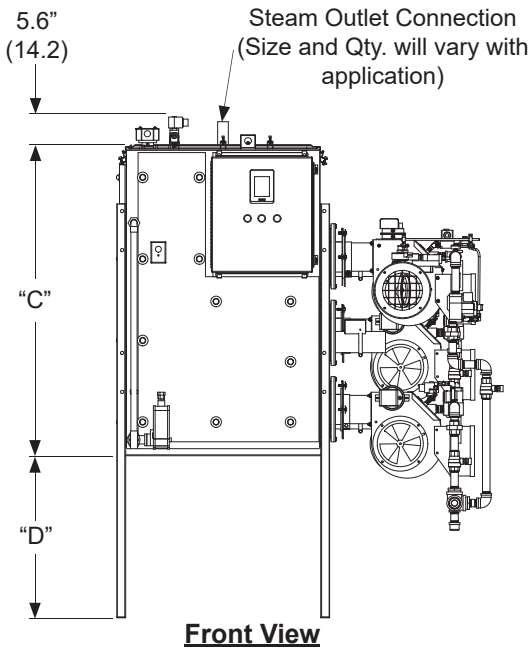
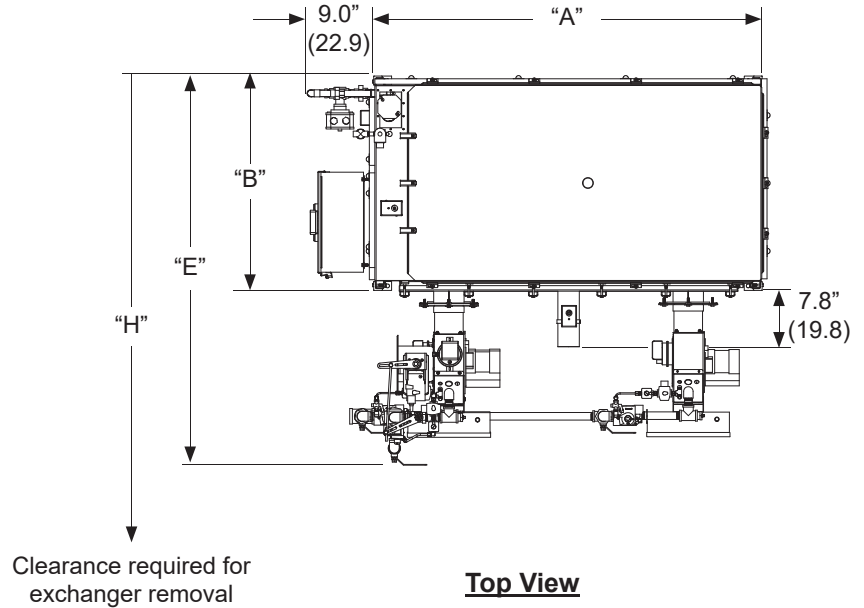

Unit Dimensions in Inches (cm)

Standard Water Unit Model No.	Dim. "A"	Dim. "B"	Dim. "C"	Dim. "D"	Dim. "E"	Dim. "F"	Dim. "G"	Dim. "H"
GX-12	54.0" (137.2)	30.1" (76.5)	43.5" (110.5)	24.0" (60.9)	55.8" (141.1)	1-1/4"-NPT	3.0" (7.6)	66.0" (167.6)

Heat exchangers have a top and bottom. There is a break (crease) on the bottom side of the heat exchanger. Do not install heat exchanger upside-down.

All dimensions are approximate and subject to change at manufacturer's discretion.

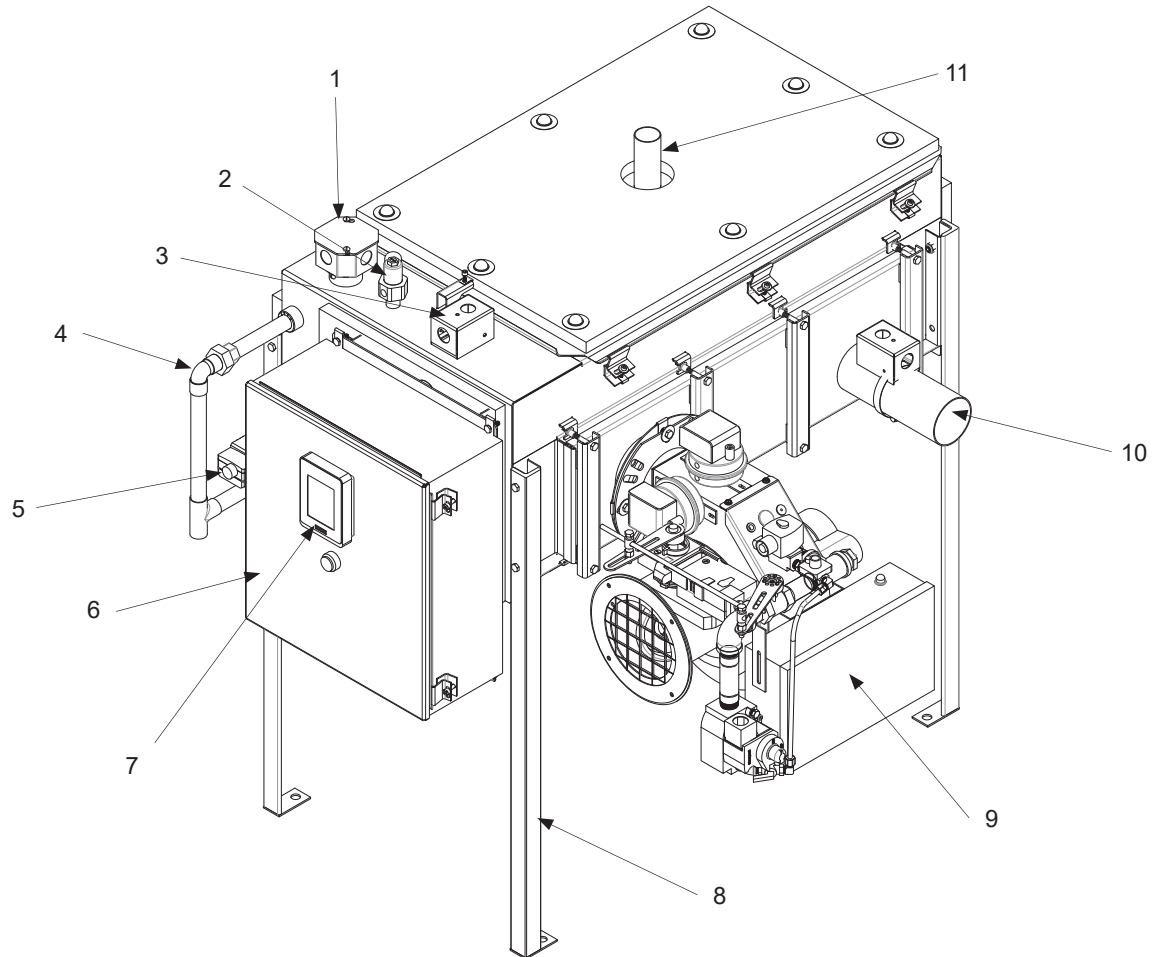

FEATURES

- | | |
|------------------------------------|-----------------------------|
| 1. Tri-Probe Sensor | 7. INTAC® PLC Controller |
| 2. 1/4"-NPT Water Inlet & Strainer | 8. Support Legs |
| 3. Over Temperature Cut-Out Switch | 9. Burner Assembly |
| 4. Flusher & Overflow Piping | 10. Exhaust Connection |
| 5. 3/4" Motorized Drain Valve | 11. Steam Outlet Connection |
| 6. Control Panel | |



Specification Sample

GX Series

SHEET NO.

GX-7

The humidifier (patent no. 6,705,535) shall be forced draft combustion gas burner type humidifier as manufactured by PURE Humidifier Co. of Chaska, Minnesota.

The humidifier shall be tested and approved by ETL/ETL-C Testing Laboratories, Inc to AGA/CGA standards.

The humidifier shall have an evaporating reservoir with a gasket sealed cover which is capable of operating at pressures of at least 19"-48 cm (W.C.) without steam or water leaks. The reservoir shall be made of type 304L stainless steel with welded joints.

The humidifier shall be designed to facilitate easy removal of the gas heat exchanger for periodic scale removal and inspection. The cover and gas heat exchanger shall be secured to the unit by the use of quick release clamps. The gas heat exchanger shall be removable from the side of the humidifier without disturbing the cover or injection tube system's steam supply piping.

The gas heat exchanger shall be constructed of type 304L stainless steel with round heat transfer tubes.

Tubes shall be self-cleaning via expansion and contraction of tubes. Coating of tubes is not required.

The humidifier shall require only 2 sides for service access.

The forced draft combustion burner shall be capable of expelling flue gases up to 100 ft (31 m) without the use of a power vent (sidewall or roof vented).

Unit shall be covered (except front face) with 3/4" (1.90 cm) thick fiberglass duct insulation. Insulation material shall have aluminum facing.

Provide support legs made of 1 1/4" x 1 1/4" x 1/4" (3.2 x 3.2 x .6 cm) angle iron and painted with gray enamel paint. Distance from humidifier bottom to floor shall be 24" (61 cm).

The humidifier control cabinet shall be factory mounted and wired to the face of the humidifier reservoir.

The humidifier is provided with a DCT-927 self-actuated drain tempering kit. The drain tempering kit is designed to provide drain and condensate water at a temperature of less than 140°F. The drain tempering kit is shipped loose.

An adjustable surface water flusher shall be included to drain away a portion of the water upon each refill cycle. This will allow mineral deposits produced by earlier evaporation cycles to be removed.

A solenoid-operated water fill valve with internal strainer shall be factory mounted on the top near the front of the humidifier reservoir. A bottom fill system shall be utilized to prevent any collapse of the steam head during the fill process. The fill valve shall be located to allow a minimum water gap of 1 1/2" (3.81 cm).

The humidifier shall have a manual reset over-temperature switch

factory installed on the humidifier reservoir. The temperature switch shall provide humidifier over-temperature protection.

A solenoid-operated water fill valve with internal strainer shall be factory mounted on the cover of the humidifier reservoir. A bottom fill system shall be utilized to prevent any collapse of the steam head during the fill process. The fill valve shall be located to allow a minimum air gap of 1 1/2" (3.81 cm).

The INTAC® Programmable Logic Controller (PLC) shall be factory mounted within the control panel and shall electronically control the automatic refilling, low water cut-off, high water cut-off, manual surface water flushing, and safety switch interlock functions. The INTAC® PLC performs self-diagnostics and controls all water level, fill, drain and safety circuit interlocks with fault indication.

The INTAC® PLC has an adjustable tank water temperature control to maintain a set temperature when the humidifier is not actively humidifying.

The INTAC® PLC shall perform Automatic drain downs. The drain period is field adjustable from 0.1 to 500 hours with the drain duration adjustable from 0.01-120 minutes. During the drain period, the humidifier reservoir will drain, and the fill valve will be energized to provide a thorough rinsing action. After the drain period is completed, the drain valve will close, and the humidifier will refill to provide humidity on demand.

The INTAC® PLC shall perform a Seasonal "End-Of-Use" humidifier drain. The humidifier will automatically drain the reservoir after a non-use time period, which is field adjustable. Upon receiving a call for humidity, the system automatically refills the reservoir and allows the humidifier to operate in "Normal Mode".

The INTAC® PLC has a local HMI display to indicate Drain Valve Open, Safety Circuit Open, Over-temp Open, Fill Valve Status, Water Level Status, Drain Valve Status and Power Output. The INTAC® PLC shall control all water level control functions through a Tri-Probe sensor mounted on the cover of the humidifier reservoir. The Tri-Probe sensor with stainless steel shield shall electrically sense the water level within the reservoir.

The INTAC® PLC also employs an intuitive color touchscreen interface, comes with BACnet communications, contains a webserver, is capable of data logging, maintains a fault history and uses a real time clock.

The INTAC® PLC will monitor the status of all gas burners and indicate a burner lockout via an internal relay closure.

The humidifier shall be provided with a JIC NEMA 12 control cabinet, shipped factory mounted and wired to the reservoir. The control cabinet shall be made of 14-gauge steel with ANSI 61 gray polyester powder coating, continuous hinge and oil-resistant gasket. The panel shall include a factory wired subpanel with gas valve interlock, Tri-Probe water level control, fused control circuit transformer, numbered terminal block and main power fuse(s).

Reference the "Options" page for a description of the options which can be added to the base specification.



Options GX Series

SHEET NO.

GX-8

Humidifier

Modulating Fill. For applications that require RH staying above a minimum threshold, a smaller fluctuation allows you to set the setpoint lower. Not only does this create a cost savings, but also saves on energy and water usage, making it a more economical option than the constant overflow method. Field-retrofittable on units that use our Tri-Probe water sensor.

Injection Tubes

Injection Tube(s) and Flexible Hose. Each unit shall include one or more 10-foot (305 cm) sections of 1½" (3.8 cm) I.D. flexible hose and a 1½" (3.8 cm) O.D. stainless steel injection tube long enough to extend across the duct. Steam ports shall direct steam upward into the airflow. The reservoir cover shall have a matching connection so the flexible hose can be connected with two stainless steel hose clamps. A two-piece duct plate shall be provided to seal the duct opening.

Fast-Pac Multiple Tube Assembly. Tube assembly consists of a stainless steel supply/condensate header with a ¾"-NPT drain connection and horizontal 1½"Ø stainless steel injection tubes.

Insty-Pac Tube Assembly. Tube assembly consists of a steam supply/seperator header constructed of stainless steel with steam inlet, condensate drain outlet, and steam jacketed injection tubes welded to header. Steam jacketed injection tubes constructed of stainless steel with punched steam ports of the proper size and spacing to deliver the maximum specified capacity.

High-Efficiency Insulated Tubes. Thermoplastic wrap reduces condensate loss and unwanted heat gain during cooling mode.

Blower Pack. Unit shall allow for direct space humidification without the use of ductwork. Unit shall be contained within a cabinet that is constructed of 18-gauge steel with a baked enamel paint finish. Unit shall have a two-speed field adjustable fan. The fan is controlled by a thermostat interlock mounted on the steam distributor, it shall activate the fan before steam is discharged and deactivate the fan after all residual steam has been discharged. One Blower Pack can be used per each 100 PPH.

Control Cabinet

Control Panel Door Lock. Control cabinet shall be provided with a factory-installed key lock on the cabinet door.

Controls and Safety Devices

VAV Control. A supply duct humidity sensor shall be supplied to control critical variable air volume (VAV) air handling systems. The system shall automatically determine if the supply air or the room/return/control by others signal is dominant and slowly reduces the humidifier output capacity, thus preventing over-saturation of the supply air when the air volume changes.

Outdoor Air Temperature Setback. Provides automatic reduction of RH set point to prevent condensation on windows during extreme cold weather.

Airflow Proving Switch. A diaphragm operated airflow proving switch with adjustable control range of .05" W.C. to 12.0" W.C. shall be provided for field installation. Switch rating shall be 2.5 amps at 120V.

Duct High-Limit. An on/off high-limit safety humidistat shall be provided for duct installation. The high-limit shall be field set to prevent over saturation within the supply duct.

Miscellaneous Accessories

DCT-927 Drain Tempering Kit. Provides cold water mixing of the 212°F drain water.

Condensate Pump. Used to lift condensate from the humidifier or tube assembly.

Outdoor Enclosure. Galvanized steel enclosure with tank freeze protection, control panel mounted, support legs, insulated tank, ventilation and hinged access doors. Enclosure is ready to be curb-mounted with the humidifier pre-installed. Ships as one piece. Roof curb is not included.

Venting

Sealed Combustion Air Kit. Consists of a 6" round adapter that allows outside air to be piped directly to the intake of the burner for combustion.

Reference the "Specification Sample" page for the humidifier base specification.