



SXDDR Series

*Deionized, Demineralized, or Reverse Osmosis Water
Steam Heat Exchanger Humidifier*

SHEET NO.

SXDDR-1

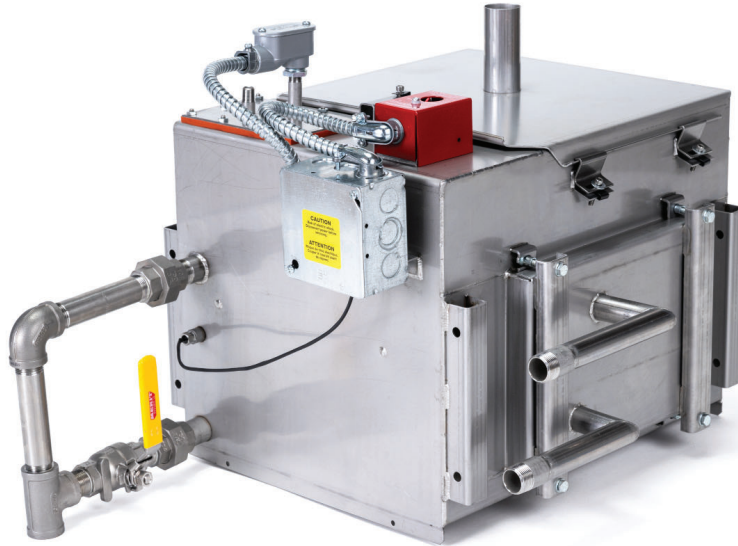

Looking for an alternative to electrically generated humidification? Concerned about using chemically treated boiler steam for direct humidification? If so, PURE's "SXDDR" Series Steam Heat Exchanger Humidifiers are exactly what you're looking for.

The "SXDDR" Series Humidifiers utilize a stainless steel heat exchanger, which allows for boiler steam to be used as the heat source for producing steam from pure water. By isolating the boiler steam from the pure water, contamination by the boiler is completely eliminated. The steam produced by the "SX" Series Humidifier is free from chemical or mineral carryover, thus providing humidification for today's stringent indoor air quality requirements. PURE's highly efficient heat exchanger produces a greater capacity per unit size than competing designs, due to the rectangular transfer tube, as well as providing simplified maintenance. Furthermore, the heat exchanger incorporates easy-to-clean rectangular transfer tubes which are simpler to maintain than round tube designs.

Each humidifier is supplied with an INTAC® PLC control system mounted in a NEMA-12 enclosure. The INTAC® PLC microprocessor control system provides constant monitoring of the water level and safety systems. This will prevent operation, should any of the safety circuits open. A control valve interlock which prevents operation should any of the safety circuits open is also provided.

When it comes to installation, you have a choice with the "SXDDR" Series Steam Heat Exchanger. The humidifier can be freestanding with a simple (optional) flexible hose connecting the unit to the stainless steel injection tube inserted through the duct wall. You can also mount the unit on the wall with wall brackets, or floor-mounted with support legs (both optional).

The versatility of the "SXDDR" Series will allow you to design them into any system simply, efficiently and reliably.

Our results are comforting



Capacities & Piping

SXDDR Series

SHEET NO.
SXDDR-2

Humidifier Capacity† & Weight										
Model	Steam Pressure at the Humidifier Control Valve								Operating Weight	
	5 psig	34.5 kPa	10 psig	69 kPa	13 psig	90 kPa	15 psig	103 kPa		
	lbs/hr	kg/hr	lbs/hr	kg/hr	lbs/hr	kg/hr	lbs/hr	kg/hr	lbs	kg
SXDDR-1R	32	14.5	76	34.5	100	45.3	122	55.3	76	34.5
SXDDR-2R	52	23.6	108	48.9	140	63.5	169	76.7	108	48.9
SXDDR-3R	102	46.3	228	103.4	292	132.5	348	157.8	228	103.4
SXDDR-4R	192	87.1	484	219.5	655	297.1	753	341.7	484	219.5

† Actual humidifier capacity may vary due to the heat loss from the humidifier reservoir. The ambient air temperature, air velocity and injection tube system will affect the rate of heat loss from the reservoir.

The capacities shown are based on a non-insulated humidifier reservoir tested in a 70°F environment.

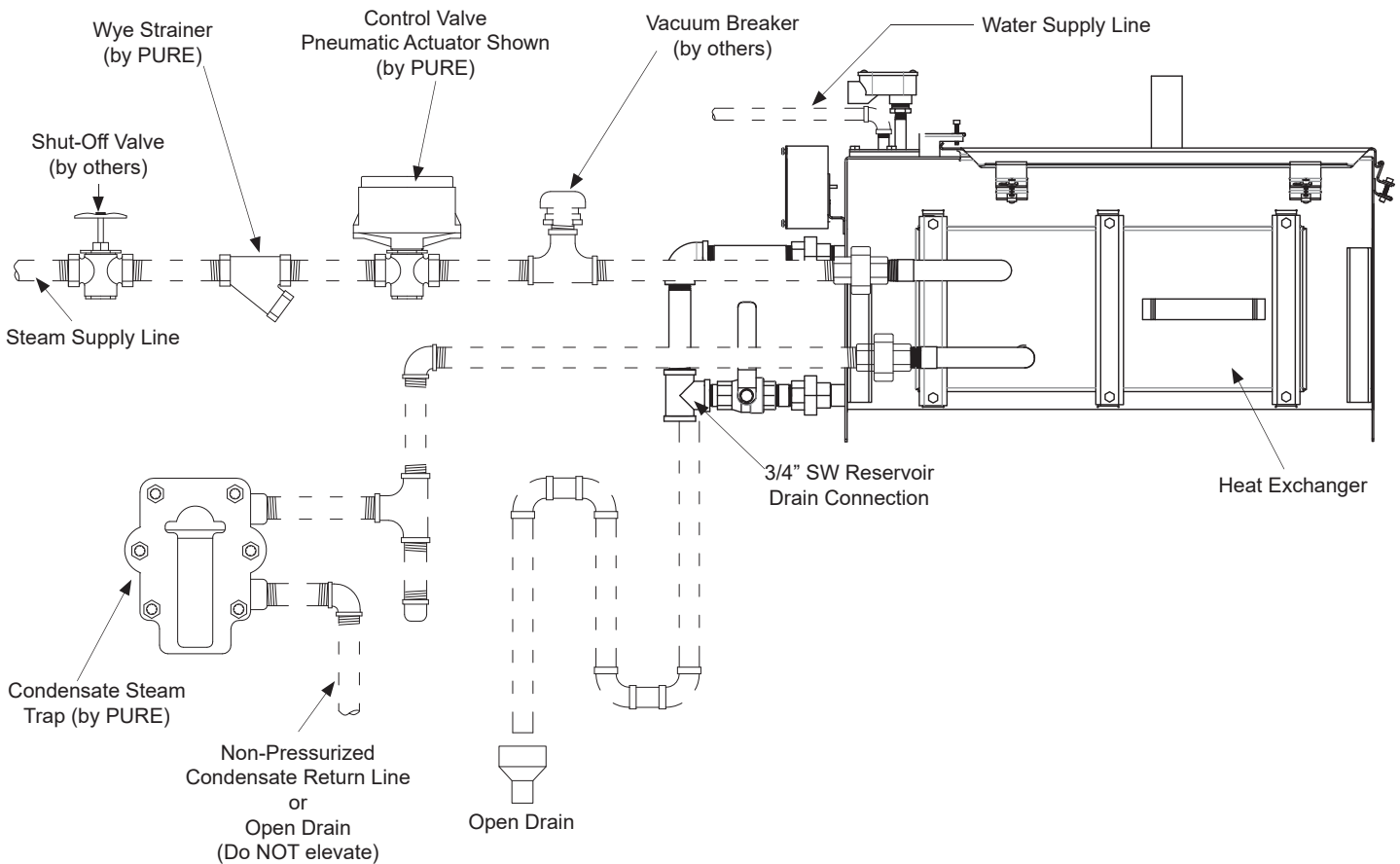

PIPING NOTES

1. Do not install piping across the front of the heat exchanger.
2. Dashed line piping is by others.
3. Do not use PVC or plastic piping for any of the piping connections to the humidifier.
4. A shut-off valve must be installed in the steam supply line prior to the wye strainer (valve by others).



Dimensions, Weights, & Layouts

SXDDR Series

SHEET NO.
SXDDR-3

NEMA 12 Humidifier Control Cabinet (reference control cabinet notes)

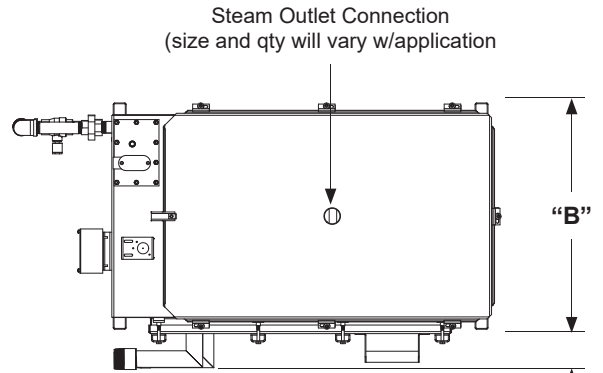
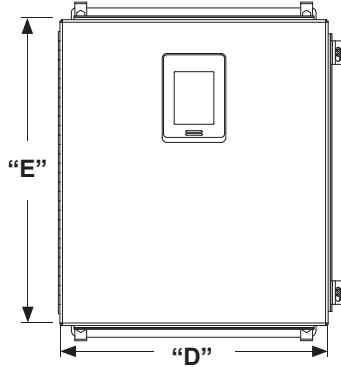

SXDDR-1R:	3.53" (8.9)
SXDDR-2R:	3.53" (8.9)
SXDDR-3R:	3.56" (9.0)
SXDDR-4R:	5.44" (13.8)

Cabinet Depth: 6.00" (15.2)

1. Door has been removed from the drawing for clarity.
2. Control cabinet is shipped loose for field mounting unless optional factory mounting is specified.
3. Control cabinet weight: 28 lbs (12.7 kg)
4. 1 Amp @ 120VAC Control circuit: 24 VAC

Top View

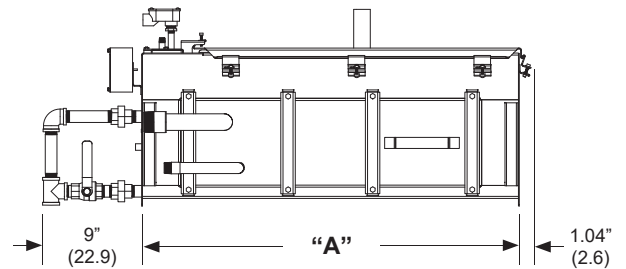
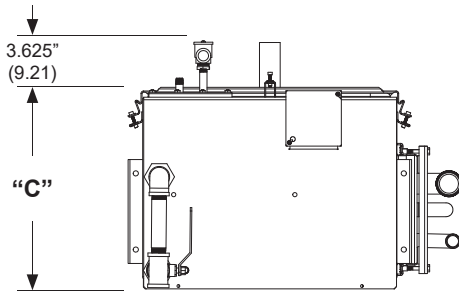

Front View

Right Side View

Unit Dimensions								
Model	Dim. "A"		Dim. "B"		Dim. "C"		Dim. "D"	Strainer
	inches	cm	inches	cm	inches	cm		
SXDDR-1R	17.68"	44.9	16.21"	41.2	13.84"	35.2	3/4" NPT	3/4" NPT
SXDDR-2R	25.68"	65.2	16.21"	41.2	13.84"	35.2	3/4" NPT	3/4" NPT
SXDDR-3R	34.18"	86.8	20.46"	52.0	13.84"	35.2	1-1/2" NPT	1-1/2" NPT
SXDDR-4R	54.12"	137.5	29.46"	74.8	13.84"	35.2	2" NPT	2" NPT

*When calculating the total dry weight of the humidifier, the control cabinet weight must be added to the reservoir weight.
Due to product improvement, catalog dimensions and specifications are subject to change without notice.



SXDDR-8R Capacities & Piping

SXDDR Series

SHEET NO.
SXDDR-4

Humidifier Capacity† & Weight										
Model	Steam Pressure at the Humidifier Control Valve								Operating Weight	
	5 psig	34.5 kPa	10 psig	69 kPa	13 psig	90 kPa	15 psig	103 kPa		
	lbs/hr	kg/hr	lbs/hr	kg/hr	lbs/hr	kg/hr	lbs/hr	kg/hr	lbs	kg
SXDDR-8R	370	167.8	840	381.0	1200	544.3	1350	612.4	840	381.0

† Actual humidifier capacity may vary due to the heat loss from the humidifier reservoir. The ambient air temperature, air velocity and injection tube system will affect the rate of heat loss from the reservoir.

The capacities shown are based on a non-insulated humidifier reservoir tested in a 70°F environment.

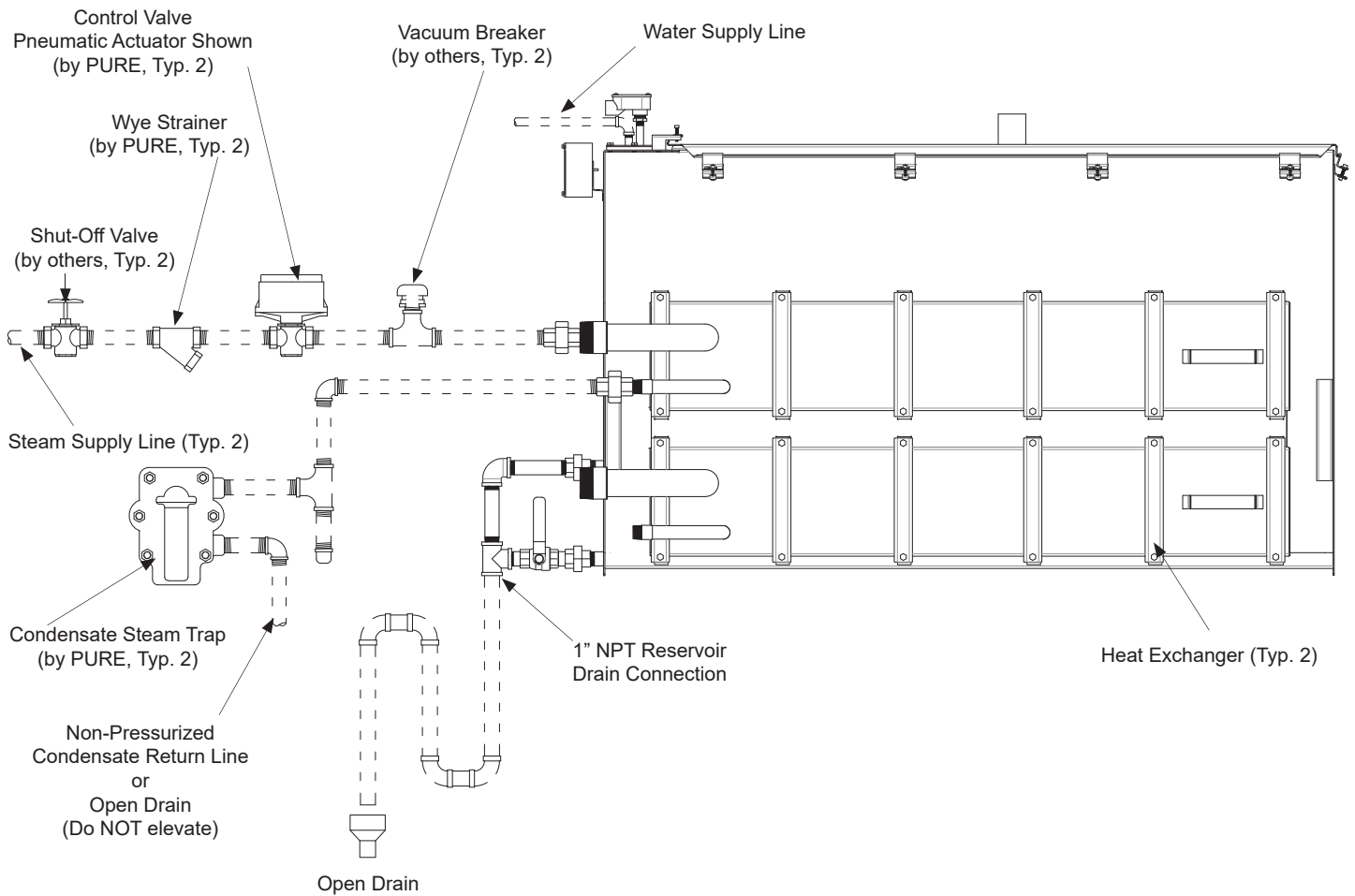

PIPING NOTES

1. Do not install piping across the front of the heat exchanger.
2. Dashed line piping is by others.
3. Do not use PVC or plastic piping for any of the piping connections to the humidifier.
4. A shut-off valve must be installed in the steam supply line prior to the wye strainer (valve by others).



SXDDR-8R Dimensions, Weights, & Layouts

SHEET NO.

SXDDR Series

SXDDR-5

NEMA 12 Humidifier Control Cabinet

(reference control cabinet notes)

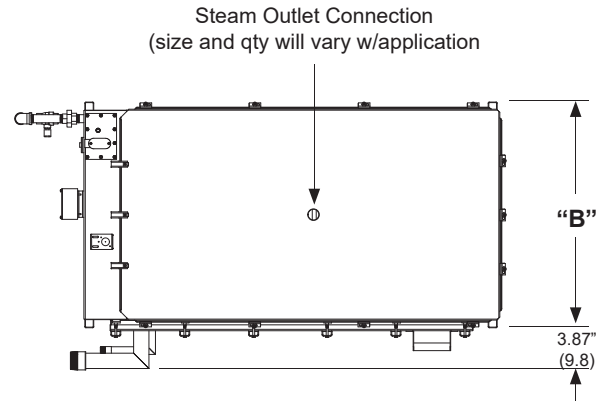
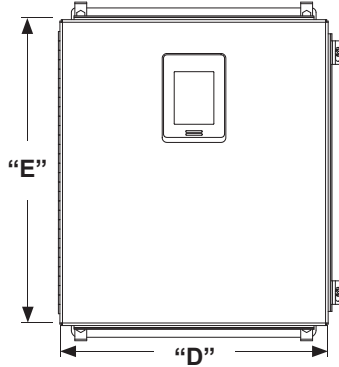

Cabinet Depth: 6.00" (15.2)

1. Door has been removed from the drawing for clarity.
2. Control cabinet is shipped loose for field mounting unless optional factory mounting is specified.
3. Control cabinet weight: 28 lbs (12.7 kg)
4. 1 Amp @ 120VAC Control circuit: 24 VAC

Top View

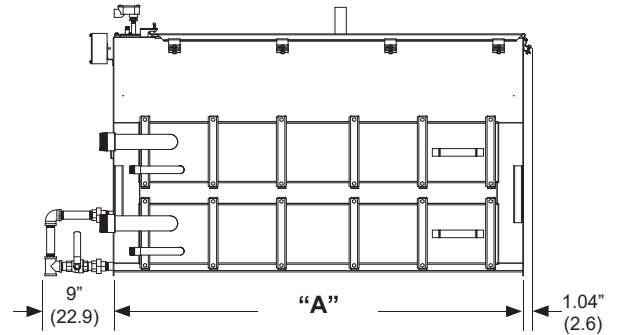
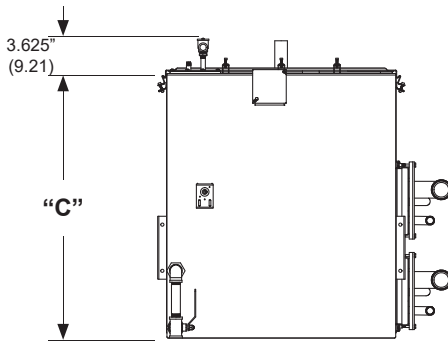

Front View

Right Side View

Unit Dimensions								
Model	Dim. "A"		Dim. "B"		Dim. "C"		Dim. "D"	Strainer
	inches	cm	inches	cm	inches	cm		
SXDDR-8R	54.12"	137.5	29.46"	74.8	31.53"	80.1	2" NPT	2" NPT

*When calculating the total dry weight of the humidifier, the control cabinet weight must be added to the reservoir weight.
 Due to product improvement, catalog dimensions and specifications are subject to change without notice.



SXDDR-12R Capacities & Piping

SXDDR Series

SHEET NO.
SXDDR-6

Humidifier Capacity† & Weight										
Model	Steam Pressure at the Humidifier Control Valve								Operating Weight	
	5 psig	34.5 kPa	10 psig	69 kPa	13 psig	90 kPa	15 psig	103 kPa		
	lbs/hr	kg/hr	lbs/hr	kg/hr	lbs/hr	kg/hr	lbs/hr	kg/hr	lbs	kg
SXDDR-12R	560	254.0	1265	573.8	1810	821.0	2035	923.1	1265	573.8

† Actual humidifier capacity may vary due to the heat loss from the humidifier reservoir. The ambient air temperature, air velocity and injection tube system will affect the rate of heat loss from the reservoir.

The capacities shown are based on a non-insulated humidifier reservoir tested in a 70°F environment.

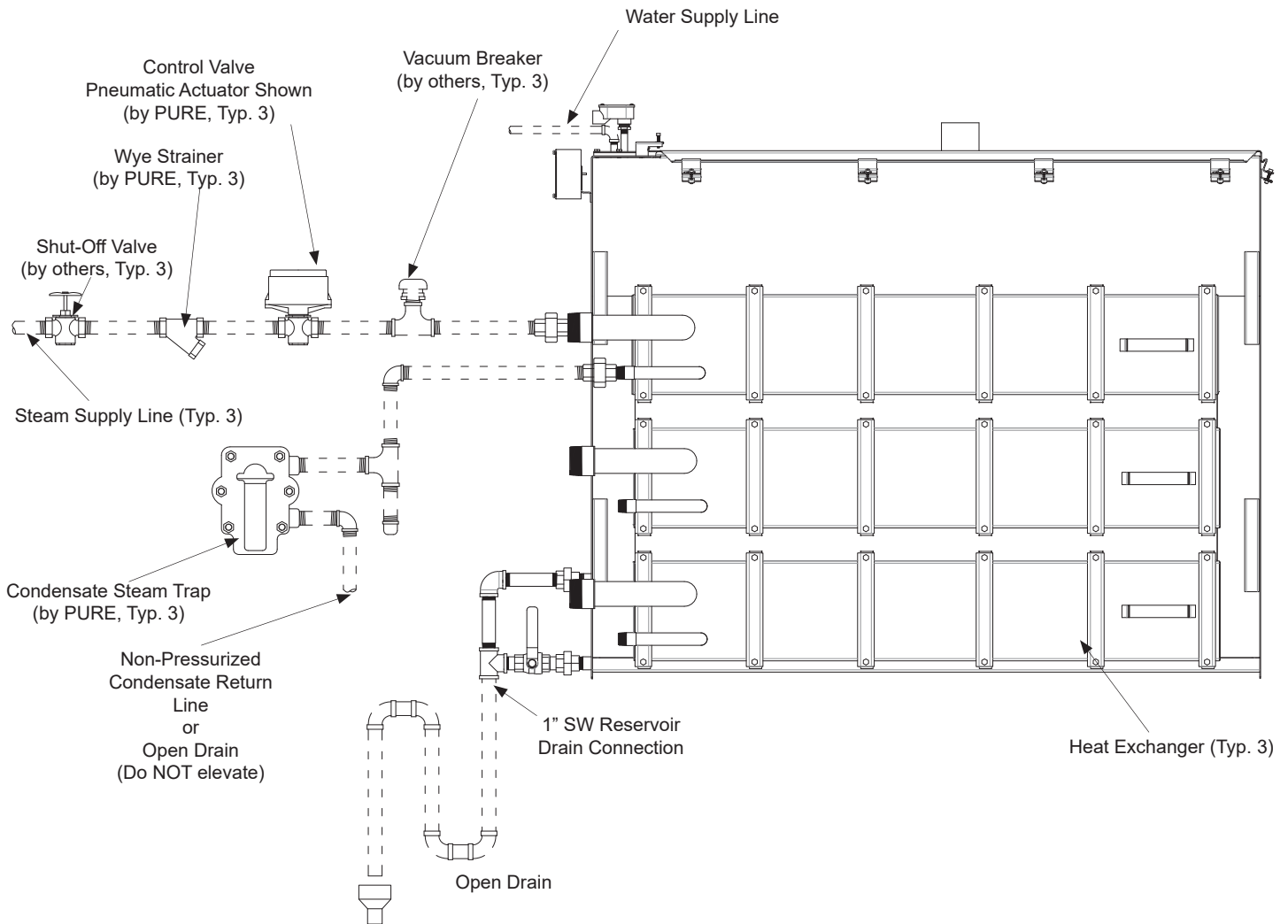

PIPING NOTES

1. Do not install piping across the front of the heat exchanger.
2. Dashed line piping is by others.
3. Do not use PVC or plastic piping for any of the piping connections to the humidifier.
4. A shut-off valve must be installed in the steam supply line prior to the wye strainer (valve by others).



SXDDR-12R Dimensions, Weights, & Layouts

SHEET NO.

SXDDR Series

SXDDR-7

NEMA 12 Humidifier Control Cabinet

(reference control cabinet notes)

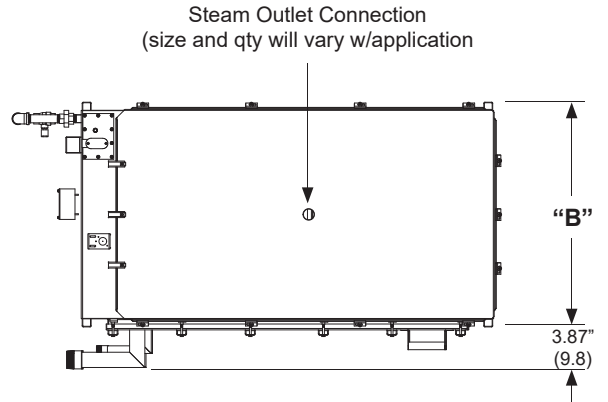
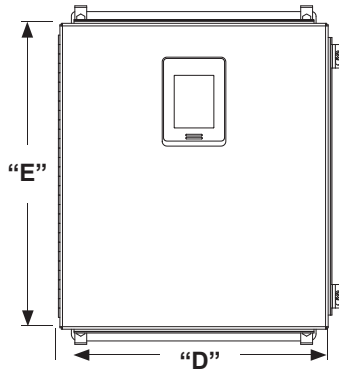

Cabinet Depth: 6.00" (15.2)

1. Door has been removed from the drawing for clarity.
2. Control cabinet is shipped loose for field mounting unless optional factory mounting is specified.
3. Control cabinet weight: 28 lbs (12.7 kg)
4. 1 Amp @ 120VAC Control circuit: 24 VAC

Top View

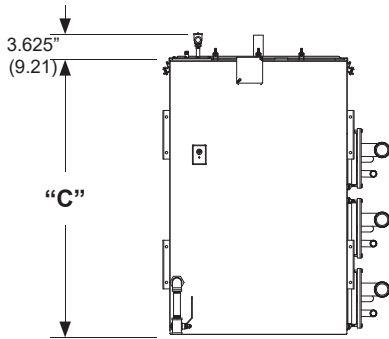

Front View

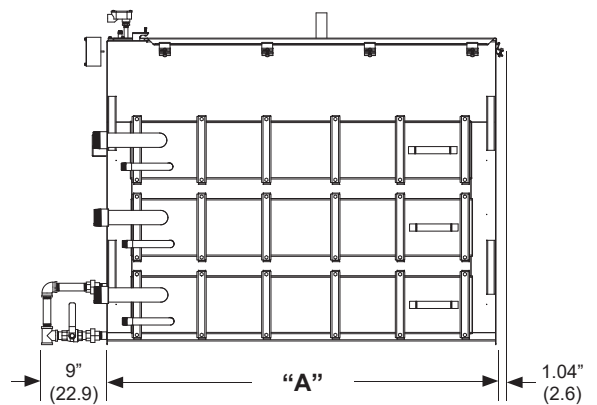

Right Side View

Unit Dimensions								
Model	Dim. "A"		Dim. "B"		Dim. "C"		Dim. "D"	Strainer
	inches	cm	inches	cm	inches	cm		
SXDDR-12R	54.12"	137.5	29.46"	74.8	42.28"	107.4	2" NPT	2" NPT

*When calculating the total dry weight of the humidifier, the control cabinet weight must be added to the reservoir weight.
 Due to product improvement, catalog dimensions and specifications are subject to change without notice.

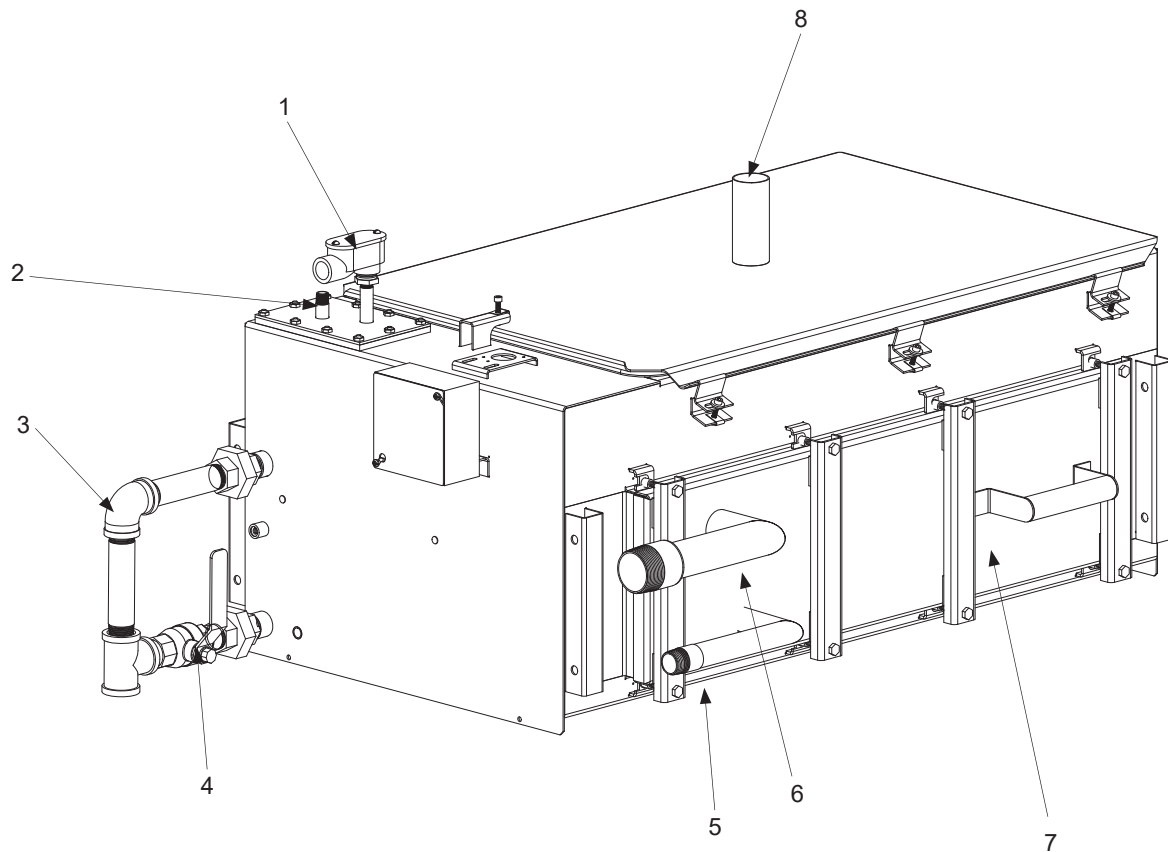

Features

- | | |
|--|---|
| 1. Low Water Float Switch Junction Box | 5. Heat Exchanger/Plant Steam Condensate Outlet |
| 2. 1/4" NPT Fill Inlet Connection | 6. Pressurized Boiler Steam Inlet |
| 3. Overflow Piping | 7. Heat Exchanger |
| 4. 3/4" NPT Ball Valve | 8. Humidifier Steam Outlet Connection |



Specification Sample

SXDDR Series

SHEET NO.

SXDDR-9

1. The humidifier shall be steam-heated heat exchanger type manufactured by PURE Humidifier Co. of Chaska, Minnesota.
2. The humidifier shall be tested and approved by ETL/ ETL-C Testing Laboratories, Inc.
3. The humidifier shall have an evaporating reservoir with a gasket sealed cover which is capable of operating at pressures of at least 19"-48 cm (W.C.) without steam or water leaks. The reservoir shall be made of type 304L stainless steel with welded joints. The reservoir shall be mounted on slide rails for easy removal from the cabinet.
4. The humidifier shall be designed to facilitate easy removal of the heater assembly for periodic scale removal and inspection. The cover and heater assembly shall be secured to the unit by the use of quick release clamps. The heat exchanger shall be removable from the side of the humidifier without disturbing the cover or injection tube system.
5. Humidifier shall be field-convertible from a steam heat exchanger style SXDDR humidifier to an electric immersion heater style ESDDR humidifier with a simple change of the side entry assembly.
6. The heat exchanger shall be constructed of type 304 stainless steel rectangular transfer tubes and headers for improved scale removal and cleaning.
7. The humidifier shall be suitable for use with pure water such as deionized, demineralized or reverse osmosis water with a maximum purity of 18 megohm-cm.
8. A stainless steel float operated low water cut-off switch shall be provided. The float switch shall provide positive low water cut-off of the humidifier immersion heaters.
9. A stainless steel float operated water fill valve mounted on the top of the humidifier shall be provided. The fill valve shall provide automatic refilling of the humidifier reservoir.
10. The humidifier shall have a $\frac{3}{4}$ " (1.9 cm) overflow pipe to prevent overfilling of the humidifier reservoir.
11. The INTAC® Programmable Logic Controller (PLC) shall be factory mounted within the control panel and shall electronically control the low water cut-off, and safety switch interlock functions. The INTAC® PLC performs self-diagnostics and controls all water level and safety circuit interlocks with fault indication.
12. The INTAC® PLC has an adjustable tank water temperature control to maintain a set temperature when the humidifier is not actively humidifying.
13. A $\frac{1}{2}$ " stainless steel ball valve shall allow for manual draining of the humidifier reservoir.
14. The INTAC® PLC has a local HMI display to indicate Safety Circuit Open, Over-temp Open, Water Level Status and Power Output.
15. The INTAC® PLC also employs an intuitive color touchscreen interface, comes with BACnet communications, contains a webserver, is capable of data logging, maintains a fault history and uses a real time clock.
16. A normally closed steam control valve with equal percentage flow characteristics that provides sufficient capacity as required shall be provided.
17. The humidifier shall be supplied with a float and thermostatic condensate trap and a pipeline wye strainer.
18. The humidifier shall be provided with a JIC NEMA 12 control cabinet, shipped loose (reference factory mounting option). The control cabinet shall be made of 14-gauge steel with ANSI 61 gray polyester powder coating, continuous hinge and oil-resistant gasket. The panel shall include a factory wired subpanel with a steam valve actuator relay interlock, INTAC® PLC, fused control circuit transformer and numbered terminal blocks. The modulating control voltage shall be field adjustable to match the controlling input signal.

Reference the "Options" page for a description of the options which can be added to the base specification.



Options

SXDDR Series

SHEET NO.
SXDDR-10

Humidifier

Insulation. Unit shall be covered (except top cover) with $\frac{3}{4}$ " (1.9 cm) thick fiberglass duct insulation. Insulation material shall have aluminum foil facing.

Steam Valve Actuator. Pneumatic modulating or electric modulating shall be supplied by PURE Humidifier Co.

Mounting

Support Legs. Provide support legs made of $1\frac{1}{4}$ " x $1\frac{1}{4}$ " x $\frac{1}{4}$ " (3.2 cm) angle iron and painted with enamel gray paint. Distance from humidifier bottom to floor shall be 24" (61 cm).

Wall Brackets. Provide two wall brackets made of $1\frac{1}{4}$ " x $1\frac{1}{4}$ " x $\frac{1}{4}$ " (3.2 cm) angle iron and painted with enamel gray paint.

Injection Tubes

Injection Tube(s) and Flexible Hose. Each unit shall include one or more 10-foot (305 cm) sections of $1\frac{1}{2}$ " (3.8 cm) I.D. flexible hose and a $1\frac{1}{2}$ " (3.8 cm) O.D. stainless steel injection tube long enough to extend across the duct. The reservoir cover shall have a matching connection so the flexible hose can be connected with two stainless steel hose clamps. A two-piece duct plate shall be provided to seal the duct opening.

Fast-Pac Tube Assembly. Tube assembly consists of a stainless steel supply/condensate header with a $\frac{3}{4}$ "-NPT drain connection and horizontal $1\frac{1}{2}$ " \varnothing stainless steel injection tubes.

Insty-Pac Tube Assembly. Tube assembly consists of a steam supply/separator header constructed of stainless steel with steam inlet, condensate drain outlet, and steam jacketed injection tubes welded to header. Steam jacketed injection tubes constructed of stainless steel with punched steam ports of the proper size and spacing to deliver the maximum specified capacity.

High-Efficiency Insulated Tubes. Thermoplastic wrap reduces condensate loss and unwanted heat gain during cooling mode.

Blower Pack. Unit shall allow for direct space humidification without the use of ductwork. Unit shall be contained within a cabinet that is constructed of 18-gauge steel with a baked enamel paint finish. Unit shall have a two-speed field-adjustable fan. The fan is controlled by a thermostat interlock mounted on the steam distributor, it shall activate the fan before steam is discharged and deactivate the fan after all residual steam has been discharged. One Blower Pack can be used per each 100 PPH.

Control Cabinet

Control Cabinet Factory Mounting. Humidifier control cabinet shall be factory-mounted and wired to the left side of the humidifier reservoir.

NEMA 4 Control Cabinet. A NEMA 4 weather-tight control cabinet shall be substituted for the standard NEMA 12 cabinet.

Control Panel Door Lock. Control cabinet shall be provided with a factory-installed key lock on the cabinet door.

Controls and Safety Devices

VAV Control. A supply duct humidity sensor shall be supplied to control critical variable air volume (VAV) air handling systems. The system shall automatically determine if the supply air or the room/return/control by others signal is dominant and slowly reduces the humidifier output capacity, thus preventing over-saturation of the supply air when the air volume changes.

Outdoor Air Temperature Setback. Provides automatic reduction of RH set point to prevent condensation on windows during extreme cold weather.

Airflow Proving Switch. A diaphragm operated air flow proving switch with adjustable control range of .05" W.C. to 12.0" W.C. shall be provided for field installation. Switch rating shall be at minimum 2.5 amps at 120V.

Duct High-Limit. A high-limit humidistat shall be provided for duct installation. The high-limit shall be field set to prevent over saturation within the supply duct.

Miscellaneous Accessories

DCT-927 Drain Tempering Kit. Provides cold water cooling of the 212°F drain water.

Condensate Pump. Used to lift condensate from the humidifier or tube assembly.

Outdoor Enclosure. Galvanized steel enclosure with tank freeze protection, control panel mounted, support legs, insulated tank, ventilation and hinged access doors. Enclosure is ready to be curb-mounted with the humidifier pre-installed. Ships as one piece. Roof curb is not included.

Reference the "Sample Specification" page for the humidifier base specification.