



READ AND SAVE THESE INSTRUCTIONS

Deionized, Demineralized, or Reverse Osmosis Water

“GXDDR” Series *Gas Fired Exchanger Humidifier*

Installation Instructions

Operation and Maintenance Manual

FOR YOUR SAFETY:

Do not store or use gasoline or other flammable vapors and liquids in the vicinity of this or any other appliance.

WARNING:

Improper installation, adjustment, alteration, service or maintenance can cause injury or property damage. Refer to this manual. For assistance or additional information consult a qualified installer, service agency, or the gas supplier.

WARNING:

If the information in this manual is not followed exactly, a fire or explosion may result causing property damage, personal injury or loss of life.

WHAT TO DO IF YOU SMELL GAS:

Do not try to light any appliance.

Do not touch any electrical switch; do not use any telephone in your building.

Immediately call your gas supplier from a neighbor's telephone.

Follow the gas supplier's instructions. If you can not reach your gas supplier, call the fire department.

IMPORTANT: Read and save this guide for future reference. This guide to be left with equipment owner.

ETL/ETLC Listed # 43438 To “IAS 12-94 Gas Fired Humidifier”

Our results are comforting



Introduction

To the user of PURE Humidifier Co.'s "GXDDR" Series Gas Fired Humidifiers

We at PURE Humidifier Co. thank you for choosing one of our quality products. PURE Humidifier Co. "GXDDR" Series humidifiers are models of simplicity to install, operate and maintain. However, they must be maintained to provide maximum operating efficiency.

PLEASE READ AND FOLLOW ALL INSTRUCTIONS CAREFULLY. PROPER OPERATION AND HUMIDITY CONTROL IS POSSIBLE ONLY WITH PROPER INSTALLATION AND MAINTENANCE.

The "GXDDR" Series Humidifier is specifically designed to operate with deionized, demineralized, or reverse osmosis water. All components that will be in contact with the water are constructed of type 304 stainless steel, incoloy, or corrosion resistant materials.

Use of mineralized (hard or soft) tap water will cause fill valve failure and void the warranty. PURE Humidifier Co.'s "GX" Series should be installed on applications that require tap water.

High chloride content in feed water can cause chloride stress cracking and chloride pitting in stainless components. Chloride stress corrosion cracking (CSCC) and chloride pitting of stainless steel components is not covered by warranty. Do not use hydrochloric acid descalers or bleach to clean the tank. Consult the factory if you are unsure about which chemical descaler to use.

To ensure proper installation of this product, it must be installed by qualified HVAC and electrical contractors, and must be in compliance with local, state, federal, and governing codes. If installed improperly this product may cause damage to property, severe personal injury, or death as a result of electric shock, burns, and/or fire.

Do not adjust any components inside humidifier control box without consulting the factory.

For indoor installation in conditioned spaces only unless supplied with an outdoor enclosure.

REMOVE INTERNAL PACKING MATERIAL FROM AROUND THE FLOAT BALL ASSEMBLY BEFORE STARTING UNIT. FAILURE TO DO SO CAN RESULT IN THE OVER-HEATING OF THE HUMIDIFIER AND POTENTIAL FIRE.

Table of Contents

Introduction	1
Safety Precautions & Installation	2
Installation & Location	3
Drain Pan Mounting	4
Electrical, Combustion and Ventilation Air	5
Gas Piping Installation	6
Gas Piping Installation (continued)	7
Venting	8
Venting (continued)	9
Sealed Combustion	10
GXDDR-8 Exhaust Manifold	11
GXDDR-12 Exhaust Manifold	12
Water Supply & Drain Piping	13
Supply Piping Examples	14
Capacities, Electrical & Weights	15
Features	16
GXDDR-3, GXDDR-4 Dimensions & Layout	17
GXDDR-8 Dimensions & Layout	18
GXDDR-12 Dimensions & Layout	19
Modulating Control Operation	20
Modulating Control Operation (continued)	21
GXDDR Prestart-Up Procedure	22
GXDDR Start-Up Procedure	23
GXDDR Burner Start-Up Procedure	24
GXDDR Burner Start-Up Procedure (continued)	25
Tool Requirements & Torque List	26
Troubleshooting	27
GXDDR Maintenance	28
Burner Troubleshooting & Maintenance	29
Burner Flame Controller Troubleshooting Guide	30
Exchanger Gasket Replacement	31
Cover Gasket Replacement Instructions	32
GXDDR-3 & GXDDR-4 Exploded Parts Drawing	33
GXDDR-3 & GXDDR-4 Parts List	34
GXDDR-8 Exploded Parts Drawing	35
GXDDR-8 Parts List	36
GXDDR-12 Exploded Parts Drawing	37
GXDDR-12 Parts List	38
Burner Parts List	39
Burner Parts Drawing	40
Maintenance Notes	41
Maintenance Notes	42

The PURE Humidifier Co. Warranty

PURE Humidifier Co. guarantees its products to be free from defects in material and workmanship for a period of two years from the date of shipment; provided the product is properly installed, serviced, and put into the service for which it was intended.

Chloride stress corrosion cracking (CSCC) and chloride pitting of stainless steel components is not covered by warranty.

PURE Humidifier Co. is obligated under the terms of this warranty to the repair or replacement of the defective part(s), excluding any labor charges, or to refund the purchase price at our option. PURE Humidifier Co. assumes no obligation for incidental or consequential damages. The above provisions are in lieu of all other guarantees, obligations, liabilities or warranties, expressed or implied.



Safety Precautions & Installation

WARNING:

Improper installation, adjustment, alterations, service, maintenance, or use can cause carbon monoxide poisoning, an explosion, fire, electrical shock, or other conditions which may cause property damage, personal injury or loss of life. Consult a qualified installer, service agency, local gas supplier, or your distributor or branch for information or assistance. The qualified installer or agency must use only factory authorized and listed kits or accessories when modifying this product. A failure to follow this warning can cause electrical shock, fire, personal injury, or loss of life.

Inspect humidifier and accessories upon arrival for damaged, missing, or improper parts. If there is a problem, call PURE Humidifier Co.

Application of this humidifier should have special attention given to vent sizing and material, gas input rate, and unit sizing. Improper installation or misapplication of the humidifier can require excessive servicing or cause permanent component failure.

Installation:

Precautions

The installation must conform to the requirements of the authority having jurisdiction, or in the absence of such requirements, to the National Fuel Gas Code, ANSI Z223.1 (latest edition). In Canada, the installation of this unit must comply with local plumbing or waste water codes and other applicable codes and with the current code CAN/CGS-B149.1 "Installation Code for Natural Gas Burning Appliances and Equipment or CAN/CGA-B149.2 "Installation Code for Propane Burning Applications and equipment."

Do **not** install in potentially explosive or flammable atmospheres laden with grain dust, sawdust, or similar airborne materials.

Installation of humidifier in high humidity or salt water atmospheres will cause accelerated corrosion, resulting in a reduction of the normal lifespan of the unit.

Humidifier must be located in a conditioned space.

To prevent premature heat exchanger failure, do **not** locate ANY GXDDR unit in areas where chlorinated, halogenated or acid vapors are present in the atmosphere.

Locate the humidifier in an area clear of combustible materials, gasoline, and other flammable vapors and liquids.

When working on equipment, observe precautions in this literature, tags, and labels attached to or shipped with the unit, and other safety precautions that may apply. **Have fire extinguisher available during start-up, adjustment procedures, and service calls.**

Do not use this appliance if any part has been under water. Immediately call a qualified service technician to inspect the appliance and to replace any part of the control system and any gas control which has been under water.

Do not lift humidifier by gas controls or gas manifold.

Should overheating occur, or the gas supply fail to shut off, shut off the manual gas valve to the appliance before shutting off the electrical supply.

Do not locate units in tightly sealed rooms or small compartments without provision for adequate combustion air and venting. Combustion air must be supplied to the confined space through a minimum of two permanent openings in the enclosure, with at least one near the bottom. They should provide a free area of one square inch per 1000 BTU per hour input rating of the unit with a minimum of 100 square inches for each opening, whichever is greater. Refer to Venting Installation information on pages 8 & 9.



Installation & Location

Important: Remove all shipping brackets and materials before operating the humidifier. Humidifier flue gases must be vented to the outside atmosphere. Power supply disconnect switch must be in the off position while making wiring connections to prevent electrical shock and equipment damage. All units must be wired in strict accordance with wiring diagram furnished with this unit.

Turn off all gas while installing the supply gas piping and field installed manual gas shut-off valve for the humidifier.

Location

The location selected must provide for electrical service, cold or hot water supply, and sanitary drain.

When selecting a location, try to keep the humidifier within 10 feet (305 cm) of the duct to avoid unnecessary heat losses and condensation within the steam supply line.

Visible "fog" will saturate and condense when it contacts objects such as turning vanes, filters, fans, elbows or take-offs. The warmer the air, the more easily it will dissipate the visible steam. The most active and warmest portion of the duct will provide better mixing of the steam and air. The injection tube should be mounted a minimum of 2 feet (61 cm) downstream from an elbow or other turbulent air-flow area.

Avoid mounting single style injection tube(s) closer than 8-10 feet (244-305 cm) upstream of objects that could become saturated and condense the steam (reference the paragraph above). If the duct layout does not provide a straight unobstructed run of 8-10 feet (244-305 cm), a multiple injection tube system should be considered to reduce the visible steam travel distance.

For Fast-Pac and Insty-Pac multiple tube assemblies please consult factory for job specific non-wetting distances.

Reference Fast-Pac or Insty-Pac O&Ms for full installation details.

CAUTION: Do not humidify upstream of filters. Consult factory.

CAUTION: Smoke detectors should not be located downstream of injection tube assemblies.

Location of Controls

It is important to avoid mounting any controls within the visible steam. The controls should be mounted a minimum of 8-10 feet (244-305 cm) downstream from the humidifier injection tube. Due to the temperature rise that exists within the visible steam dissipation area, thermostats should not be mounted near the injection tube.

High-limit humidistats should be installed before any duct obstruction to make sure the humidifier is interrupted before saturation can occur on the object. The high-limit should be mounted a minimum of 8-10 feet (244-305 cm) downstream from the injection tube. Installing the high-limit closer than 8 feet (244 cm) from the humidifier may cause erratic control.

Drain Pan Mounting

A drain pan is an additional safety feature which may be required to be supplied in the field. In a proper humidifier installation, a drain pan is not required. However, if the humidifier and injection tube are located in an area that contains valuable equipment or is a water sensitive area, PURE Humidifier Co. recommends the addition of a drain pan under the humidifier and under the injection tube. The drain pan should extend past all edges of the humidifier and if installed in the duct, it should extend a minimum of 3 feet (91 cm) downstream from the injection tube. The pan should be of a size which is capable of draining at a rate of 3 gpm for units with a capacity of up to 200 lbs/hr, and 5 gpm for units with a capacity over 200 lbs/hr. The pan should be drained to a sanitary drain.

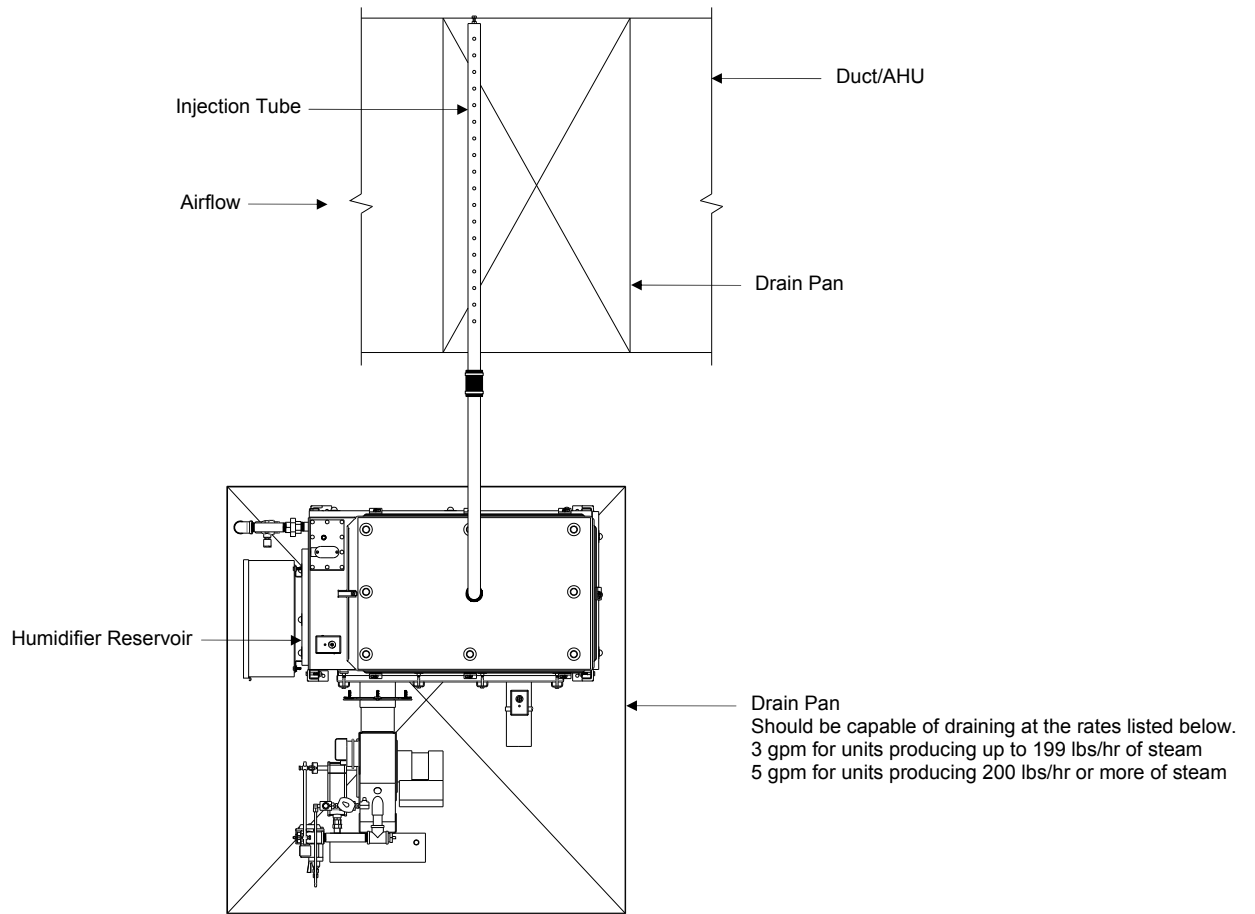

Humidifier Reservoir and Injection Tube Plan View



Electrical, Combustion and Ventilation Air

Electrical

WARNING:

The cabinet **must** have an uninterrupted or unbroken ground according to National Electrical Code, ANSI/NFPA 70 and Canadian Electrical Code, CSA C22.1, or local codes to minimize personal injury if an electrical fault should occur. This may consist of electrical wire or conduit approved for electrical ground when installed in accordance with existing electrical codes. Do not use gas piping as an electrical ground.

Connect copper ground wire to cabinet ground lug.

Humidifiers should be supplied with 120-volt AC, 60 Hz, 15-amp separately fused electrical service. The humidifier is equipped with a transformer to step down the voltage to 24 VAC control voltage.

When installed, the humidifier must be electrically grounded in accordance with local codes, or in the absence of local codes, with the National Electrical Code ANSI/NFPA No. 70-1987. The electrical conductors shall be a minimum Type MTW (105°C) AWG #14 wire for line voltage (120V), with BLACK WIRE for HOT; WHITE WIRE for NEUTRAL, GREEN WIRE for GROUND; and minimum #18 gauge for control wiring. All electrical components and wiring must be protected from mechanical damage and water. The control system requires an earth ground for proper operation.

The humidifier is adjusted for correct performance. Do not alter fan or operate motors at reduced speed.

The current characteristics, and capacity requirements should be checked against the nameplates. All wiring must be in accordance with all governing codes, and with wiring diagram located inside the control cabinet.

See separate publication for the INTAC® controller furnished with this humidifier.

Combustion and Ventilation Air

CAUTION:

Air for combustion must not be contaminated by halogen compounds, which include fluoride, chloride, bromide and iodide. These elements are found in aerosol sprays, detergents, bleaches, cleaning solvents, salts, air fresheners, and other household products.

CAUTION:

The operation of exhaust fans, kitchen ventilation fans, clothes dryers, or fireplaces could create a negative pressure condition at the humidifier. Make-up air must be provided for the ventilation devices, in addition to that required by the humidifier.

All fuel burning equipment must be supplied with air for combustion of the fuel. Sufficient air **MUST** be provided to ensure there will not be a negative pressure in the equipment room or space.

Provisions for adequate combustion and ventilation air must be provided in accordance with Section 5.3, Air for Combustion and Ventilation, of the National Fuel Gas Code ANSI Z223.1 1-1988, or applicable provisions of the local building codes. Canadian installations must be installed in accordance with sections 7.2, 7.3, and 7.4 of the CAN/CGA.B149 Installation Codes, and all authorities having jurisdiction.



Gas Piping Installation

CAUTION:

Gas pressure to humidifier controls must never exceed 14" W.C. (1/2 psi).

Contact your local gas service company to ensure that adequate gas service is available, and to review applicable installation codes for your area. All gas piping installations must be in accordance with codes, and ANSI Z233.1, "National Fuel Gas Code," or CAN/CGA-B149 in Canada.

Do not use flexible connectors.

Piping to units should conform with local and national requirements for type, volume, gas handled, and pressure drop allowed in the line. Refer to tables 1 and 2 to determine the cubic feet per hour (cfh) for the type of gas and size of unit to be installed. Using this value and the length of pipe necessary, determine the pipe diameter. Where several units are served by the same main, the total capacity, gas flow (cfh), and length of main must be considered. The figures shown are for straight lengths of pipe at 0.2" w.c. pressure drop, which is considered normal for low-pressure systems. Note that fittings such as elbows and tees will add to the pipe pressure drop.

After threading and reaming the ends, inspect piping and remove loose dirt and chips.

Support piping so that no strains are imposed on unit or controls.

Use two wrenches when connecting piping to unit controls.

Provide a drip pocket before each unit and in the line where low spots cannot be avoided.

Take-off to unit should come from top or side of main to avoid trapping condensate.

Piping subject to wide temperature variations should be insulated.

Pitch piping up toward unit at least 1/4" per 15' of horizontal run.

Compounds used on threaded joints of gas piping must be resistant to the harmful action of liquefied petroleum gases.

Purge air before lighting unit by disconnecting piping at gas control. **In no case should the line be purged into heat exchanger.**

Install pressure regulator directly upstream of main automatic gas valve(s) and fit drip leg main gas cock upstream of regulator or automatic valve(s).

Install vent lines from main gas regulator (if used) and diaphragm gas valve where applicable. Vent lines should be run to the outside of the building, terminating clear of windows or fresh air intakes. Outside termination of vent should have a screen to prevent insects from building nests in vent pipe.

Install a ground joint union and a manual gas shut-off valve immediately upstream of the unit including a 1/8" NPT plugged tapping accessible for test gauge connection.

Allow at least 5 feet of piping between any high pressure regulator and unit pipe connection.



Gas Piping Installation (Con't)

Gas Leak Testing

When testing the gas supply piping system, the humidifier and its gas shut-off valve must be disconnected during any pressure testing in excess of 14" W.C. (1/2 psi). The humidifier must be isolated from the gas supply piping system by closing its field-installed manual shut-off valve during any pressure testing equal to or greater than 14" W.C. (1/2 psi).

Test gas lines for leaks using a soap solution. Your local gas service company may wish to execute or witness this test. CAUTION: Gas pressure above 14" W.C. may damage the standard diaphragm gas shut-off valve. Do not exceed this value when pressure testing lines unless you cap-off line upstream of main gas cock and pilot take-off.

Check gas supply pressure with all burners running at inlet pressure tap of gas control. The recommended supply pressure should be 7" W.C. on natural gas or 11" W.C. on LP gas. Purging of gas piping should be performed as described in ANSI Z223.1 (latest edition), or in Canada in CAN/CGA-B149 codes.

Minimum supply pressure. Natural - 5" W.C. LP - 5" W.C.

Gas valves outlet pressure (manifold) shall be factory set. **This pressure can be checked at the 3/4" tee after the orifice.** See humidifier label for correct pressure rating.

**Table 1 - Gas Input CFH
for GXDDR-Series Humidifiers**

Model No.	Max BTU/hr Input	Max CFH (Nat. Gas)	Max CFH (Propane)
GXDDR-3	150,000	150	60
GXDDR-4	400,000	400	160
GXDDR-8	800,000	800	320
GXDDR-12	1,200,000	1,200	480

Table 2 - Gas Piping Pressure Drop Data

EQUIVALENT LENGTH OF STRAIGHT PIPE IN FEET									
	20	30	40	20	60	80	100	150	200
CFH GAS WITH .2" PRESSURE DROP									
Pipe Size in Inches									
3/4"	152	120	105	93	84	73	66	54	45
1"	300	250	210	190	180	150	135	110	75
1 1/4"	520	425	360	325	300	260	230	190	165
1 1/2"	800	690	560	500	480	410	370	300	260
2"	1700	1400	1200	1100	1000	850	750	600	540
2 1/2"	3000	2500	2100	1900	1800	1550	1375	1100	950
EQUIVALENT LENGTHS OF STANDARD PIPE IN FEET FOR LISTED FITTINGS									
Fitting Type	3/4	1	1 1/4	1 1/2	2	2 1/2	Nominal		
Std. Tee	2.4	5.5	7.5	9	12	13.5	Pipe Size		
Std. Elbow	4.4	2.7	3.7	4.5	5.5	6.1	in Inches		



Venting Installation

For proper and safe operation this appliance needs air for combustion and ventilation. DO NOT block or obstruct air openings on the appliance, spaces around the appliance, or air openings communicating with the appliance area.

DO NOT block the flow of combustion and ventilation air. To provide for necessary oxygen for proper combustion, opening must be provided to allow outside air to enter the space in which the heater is located. Enclosed spaces, such as equipment rooms, must be vented at the blower for combustion air. The size of air openings must be based on all gas-burning equipment installed in the space involved. Provisions for adequate combustion and ventilation air in accordance with Section 5.3, Air for Combustion and Ventilation, of the National Fuel Gas Code, ANSI Z223.1, or Sections 7.2, 7.3 or 7.4 of the CAN/CGA B149 Installation Codes, or applicable provisions of the local building codes.

The burner should be initially set up and serviced at regular intervals (preferably at the beginning of and mid-way through high use period) by a trained serviceman using the proper test instruments. Failure to maintain the correct burner settings may result in inefficient gas consumption, premature wear of burner components, or explosion hazard.

Venting

The GXDDR Series Humidifiers are Category 3 Appliances.

The purpose of venting the gas humidifier is to completely remove all products of combustion and ventilation gases to the outside air, without condensation in the stack.

When connecting the humidifier to a gas vent or chimney, the installation shall be in accordance with Part 7, Venting of Equipment, of the National Fuel Gas Code, ANSI Z223.1, or Section 7, Venting Systems and Air Supply Appliances, of the CAN/CGA-B149 Installation Codes, the local building codes, and the vent manufacturer's instructions.

Do not reduce the vent diameter, and avoid short turns in the vent piping. Use the exhaust manifold vent size shown on page 15

Allow for removal of air intake and exhaust connections for heat exchanger cleaning and regular maintenance. Maintain a 1/4-inch-per-foot pitch for horizontal runs. Maintain proper support of vent connections and joints. Observe clearances (in accordance with applicable codes) from all combustible materials, and obtain an approved cap for the stack outlet. The bottom of the cap must be one stack diameter above the top of the stack.

Inspect for proper and tight construction. Any restrictions or obstructions must be removed. An existing chimney may require cleaning.

Chimney or vent must extend at least 3 feet above its passage through a roof and at least 2 feet above any ridge within 10 feet of the chimney (local codes apply).

Minimum clearance from the vent connector to combustible material is 6 inches unless the combustible materials are protected in accordance with applicable codes.

PURE Humidifier requires humidifiers be connected to vent systems sufficient for use with Category 3 Appliances (listed to UL Standard 1738 or ULC-S636). Any condensate formed is acidic and could cause corrosion of the vent materials. This humidifier must not be connected to a chimney flue servicing a separate appliance designed to burn solid fuel.

Install a condensate trap at the bottom of exchanger stack.

Never connect this humidifier to a chimney.

Venting into an unlined masonry or concrete chimney is prohibited by code.

Insulation must be added to any vent connector which will be exposed to ambient temperatures of 30°F or less.

Do not insulate vent pipe exposed to outdoor weather conditions (i.e. above roof lines).

Installation of the vent pipe should be as direct as possible, with a minimum number of turns or elbows.

Rigidly support the vent pipe every 5 feet or less with hangers or straps to ensure that there will be no movement or sagging after installation. The humidifier vent box should not be supporting the weight of the vent piping.



Venting Installation (Con't)

No portion of the vent system shall extend into, or pass through, any circulation air duct or plenum.

The vent system shall terminate above the roof surface per the National Fuel Gas Code or CAN/CGA.B149 requirements, and shall include a UL or CUL listed vent cap or roof assembly, unless prohibited by local codes.

All vent pipe passing through floors, ceilings, and walls must be installed with the proper clearances from combustible material, and be fire-stopped according to the National Fuel Gas Code requirements and Canadian Standards CAN/CGA.B149.

In replacement installation, where an existing vent system may be used, the vent system must be inspected for condition, size, type of vent material, and height to meet the requirements in these instructions. If the existing vent system is too large, condensation could occur, causing corrosion of the vent system. Installing a replacement vent system may be required.

Horizontally Vented Humidifier

Maintain a minimum upward slope of 1/4-inch per linear foot on all horizontal vent pipe runs. If condensate in venting is noticed, a condensate trap must be installed.

Rigidly support the vent pipe at intervals no longer than five feet with hangers or straps to ensure there will be no movement after installation. The humidifier exhaust termination should not be supporting the weight of the vent piping.

Distances from the vent terminal adjacent public walk ways, buildings, and openable windows and building openings should be consistent with the National Fuel Gas Code, ANSI Z223.1, and/or CAN/CGA.B149 Installation Codes.

The vent terminal location must be at sufficient height above ground level to prevent blocking by expected snowfall.

Building materials should be protected from degradation by flue gases.

A minimum horizontal clearance of 4 feet (1.22m) from electric meters, gas meters, regulators, and relief equipment must be maintained.

Venting Requirements

100' maximum equivalent length of vent pipe.

90° Elbow = 10'

45° Elbow = 5'

Maximum of 4 elbows.

Vent pipe is to be rated for Category 3 Appliances listed to UL Standard 1738 or ULC-S636 (AL29 4C).

Allow for removal of air intake and exhaust connections for heat exchanger cleaning and regular maintenance.



Sealed Combustion

Sealed Combustion Air Kit. Consists of a 6" round stainless steel adaptor to connect to field installed combustion air piping. Use of this kit will allow the burner to intake combustion air from outside instead of using room air.

Benefits:

Sealed combustion burners can save energy because they don't steal heated or cooled indoor air.

Sealed combustion burners reduce space heating costs and noise while eliminating problems associated with power-vented combustion.



GXDDR-8 Exhaust Manifold

Reference pages 8 & 9 for venting installation instructions.

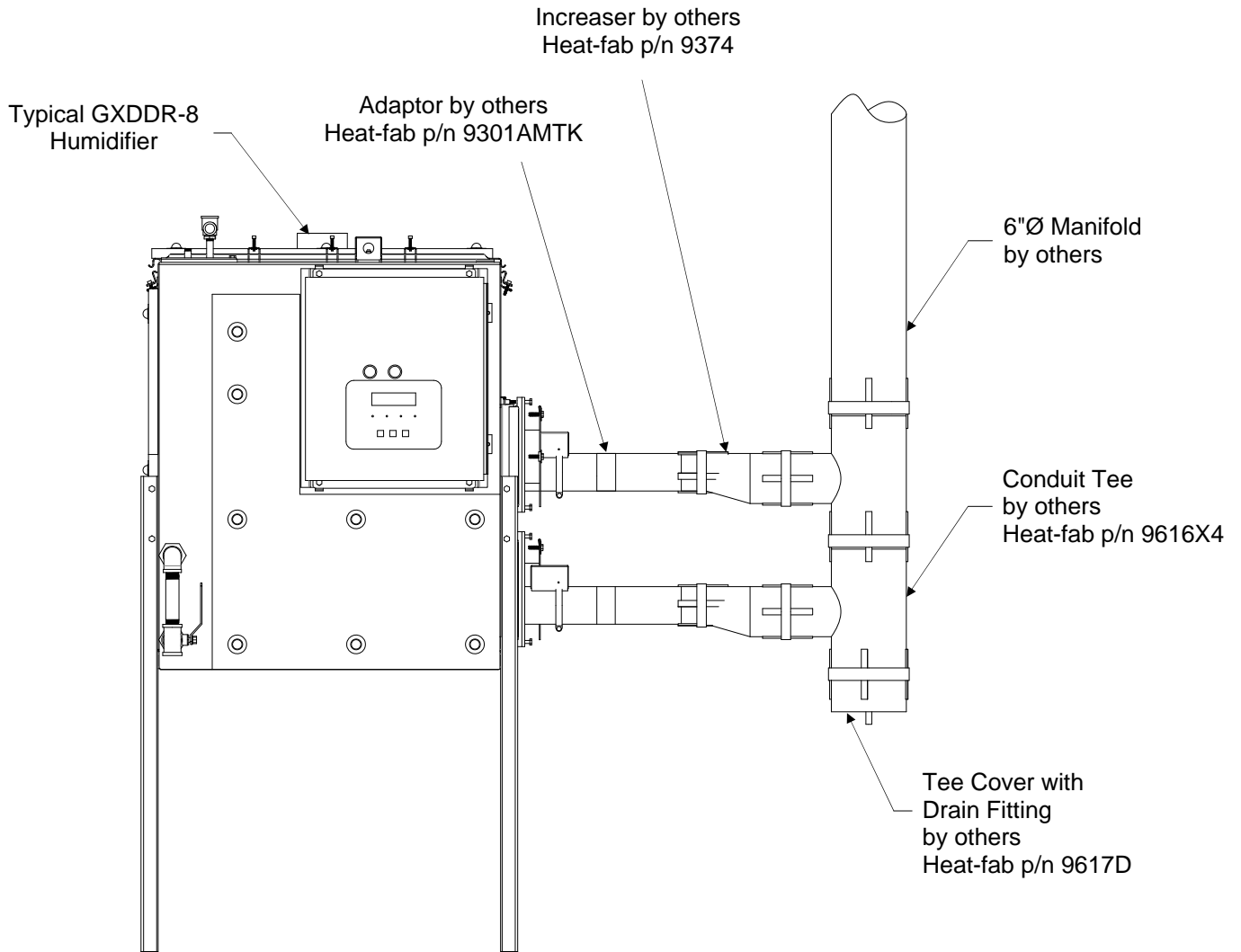

All exhaust connections and piping to be Category 3 Appliance Listed to UL Standard 1738 or ULC-S636



GXDDR-12 Exhaust Manifold

Reference pages 8 & 9 for venting installation instructions.

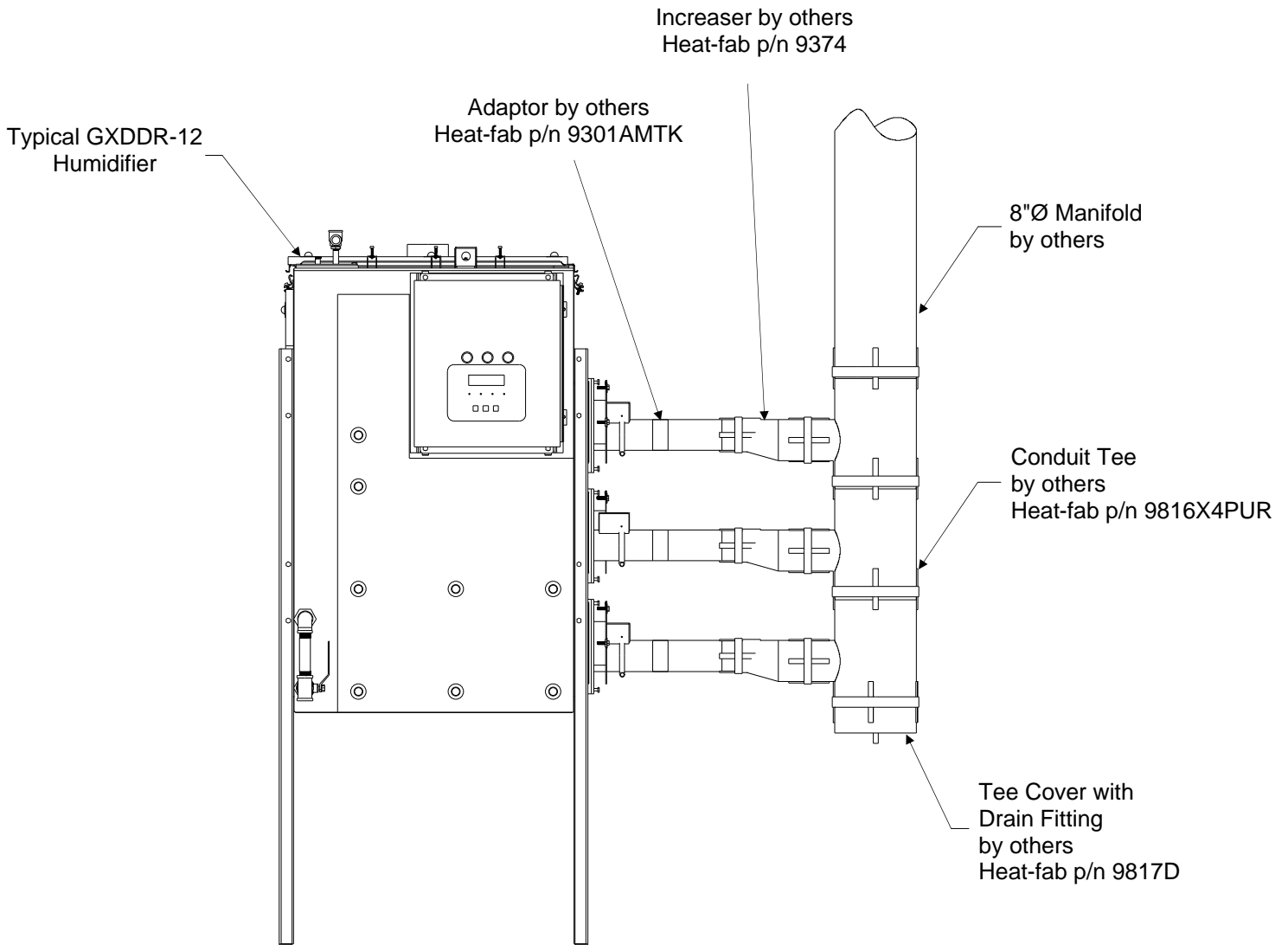

All exhaust connections and piping to be Category 3 Appliance Listed to UL Standard 1738 or ULC-S636



Water Supply & Drain Piping

Water Supply Piping

Supply pressure: 35-50 psi

This style humidifier utilizes a float operated fill valve system which is designed for use with deionized, demineralized, or reverse osmosis water. Use of mineralized tap water will cause fill valve failure and will void the humidifier warranty.

Install stainless pipe on make-up water line within 5 ft of humidifier fill valve connection. If plastic pipe is used beyond this point a check valve is required to prevent steam from entering the plastic section in the event that the water treatment system runs out of water.

The water source for use in the GXDDR humidifier should be from a single pass reverse osmosis or dual bed deionizer system. Extremely high purity water **should not** be used. Examples of extremely high purity water are: water treated by a reverse osmosis followed by a mixed bed deionizer, or two mixed bed deionizers in series. Water produced by these multistage systems will typically be produced with conductivity of less than 1 microsiemens. If the source for the humidifier must come from a water "loop" with conductivity of less than 1 microsiemens, install a calcite cartridge filter in the water supply line feeding the GXDDR humidifier tank. The cartridge will need to be replenished periodically. A minimum water pressure of 35 psi (2.4 Bar) should be maintained to provide the proper water level within the humidifier. Adjustment of the float valve will be necessary if the pressure is lower than 35 psi (2.4 Bar). If the water pressure is above 50 psi (3.5 Bar), the valve may not shut off.

REMOVE INTERNAL PACKING MATERIAL FROM AROUND THE FLOAT BALL ASSEMBLY BEFORE STARTING UNIT. FAILURE TO DO SO CAN RESULT IN THE OVER-HEATING OF THE HUMIDIFIER AND POTENTIAL FIRE.

Drain Piping

A water seal as shown in the piping illustration should be installed to prevent steam from escaping through the drain line. The water seal should be of sufficient height to overcome the pressure developed in the humidifier (reference water seal height table) and the duct static pressure.

The drain piping should be stainless steel. The use of PVC piping is not recommended; the humidifier temperature will cause the PVC to soften and fail.

If gravity drain is not possible please use a condensate pump rated for 212°F water or contact a PURE Humidifier Co. Representative to purchase one.

Water Seal Height Δ

Total lbs./hr (kg./hr)	"H"
Up to 60 (27.2)	8" (20 cm)
61 to 99 (44.9)	11" (28 cm)
100 to 150 (68.0)	17" (43 cm)
151 and up	19" (48 cm)

Δ The water seal height may have to be increased if excessive duct static pressure exists

NOTES

1. All drain piping is by others.
2. Drain and overflow connection requires field piping.
3. Do NOT use PVC or other plastic piping that is not rated for 220° F. or higher.

† The humidifier has a 1.5" (4 cm) air gap between the water inlet and humidifier water level. Consult the local code to determine if a vacuum braking device is required.

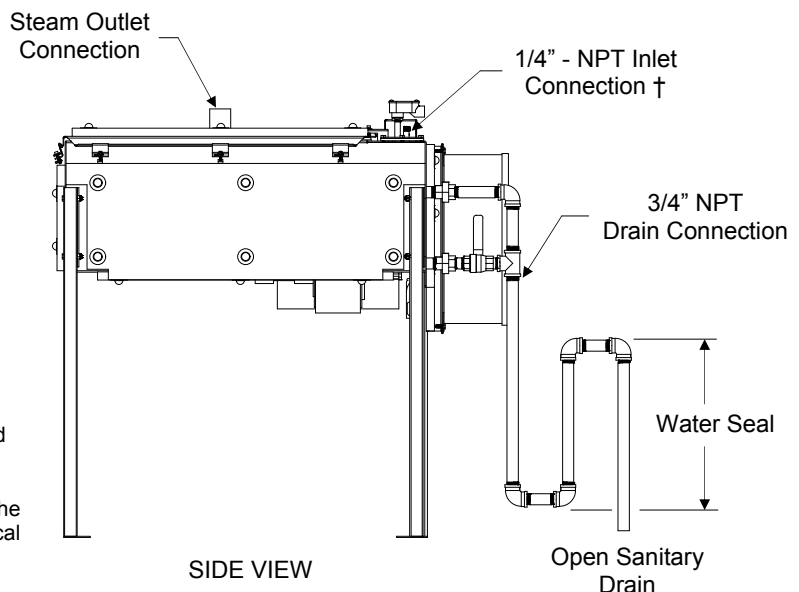

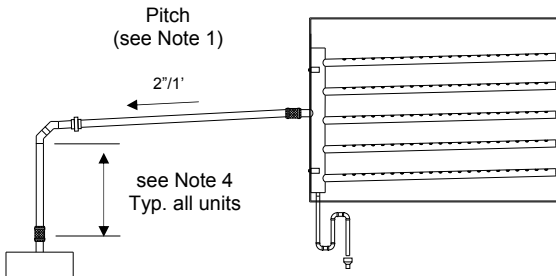

Pitched Towards Steam Generator

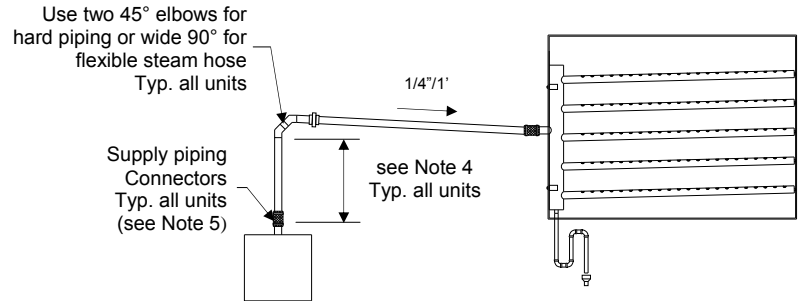

Pitched Towards Tube Assembly

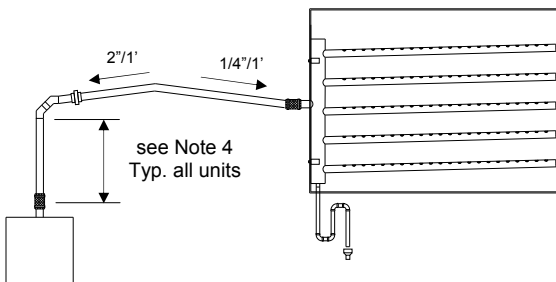

Pitched Towards Steam Generator and Tube Assembly

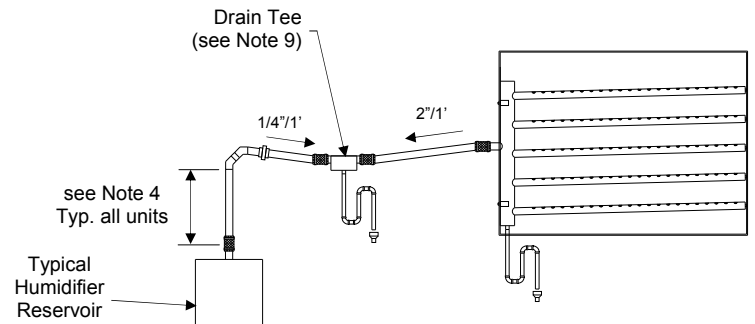

Pitched Towards Drain Tee

Notes:

1. Flexible steam hose can be used for runs up to 10' in length. For runs over 10' in length, use hard piping.
2. Recommended supply piping material: Black iron pipe, copper, or stainless steel.
3. Pitch hard piping or flexible hose 2" per foot or more if steam is flowing uphill, 1/4" per foot if the steam is flowing downhill. Reference piping examples shown.
4. Install a minimum two-foot or greater riser from the top of the tank to reduce condensate carry over.
5. Use flex connectors or unions to allow for easy removal of cover.
6. Support flexible hose every 18" to avoid sagging.
7. Hard piping or flexible hose must match reservoir outlet size. Do not use supply piping with a smaller inside diameter than the reservoir outlet. Longer supply runs may require a larger diameter pipe.
8. Failure to follow the piping recommendation on this page may result in blown water seals, leaking cover gasket, or dispersion tubes spitting.
9. Install a Drain Tee at any low spots in supply piping run where condensate will accumulate.
10. Reference job specific tube assembly O&M included with your order for complete details.

For installations using deionized water fed humidifiers, PURE recommends stainless tubing or pipe to match the outlet diameter connection on the evaporating chamber. Stainless has superior corrosion resistance over copper and is less expensive but slightly harder to install. Stainless tubing is preferable over stainless pipe due to the fact that the tubing is less expensive and requires less heat/condensate during operation. Stainless pipe may be easier to install compared to stainless tubing because fittings are readily available and it does not require welding. As always, the installer should refer the material required by the project documents and/or the authority having jurisdiction.



Capacities, Electrical & Weights

This humidifier is a forced combustion type that can be used with natural gas or liquid propane. The burner can be easily removed to access the side entry exchanger(s) for cleaning. It is designed to work with low-pressure gas between 5" W.C. up to 14" W.C.

Unit Capacities in Pounds per Hour (Kg/Hr)† Weights in lbs. (kg) and Electrical Specification

Model No.	Steam Capacity Lb/Hr (kg/Hr)	No. of Burners	*BTU Input	#Exhaust Manifold Vent Size (cm)	Shipping Weight (kg)	Operating Weight (kg)	120 Volt, 60 Hz
							Full Load Amps
GXDDR-3	110 (49.9)	1	150,000	4" (10.2)	201 lbs. (91.2)	420 lbs. (190.5)	5.0
GXDDR-4	300 (136.1)	1	400,000	4" (10.2)	390 lbs. (176.9)	710 lbs. (322.1)	5.0
GXDDR-8	600 (272.2)	2	800,000	6" (15.2)	827 lbs. (375.1)	1391 lbs. (630.9)	10.0
GXDDR-12	900 (408.2)	3	1,200,000	8" (20.3)	1125 lbs.(510.3)	2072 lbs. (939.9)	15.0

† Actual humidifier capacity may vary due to the heat loss from the humidifier reservoir. The ambient air temperature, air velocity and injection tube system will affect the rate of heat loss from the reservoir.

* Altitude adjustment:

100% up to 2000'

Over 2000', 4% de-rate per 1000'

Vent Size is larger than connection size.

Reservoir Water Volume in Gallons (Liters)

Model No.	Water Volume In Gal (Liters)
GXDDR-3	22 (83.3)
GXDDR-4	48 (181.7)
GXDDR-8	94 (355.8)
GXDDR-12	143 (541.3)

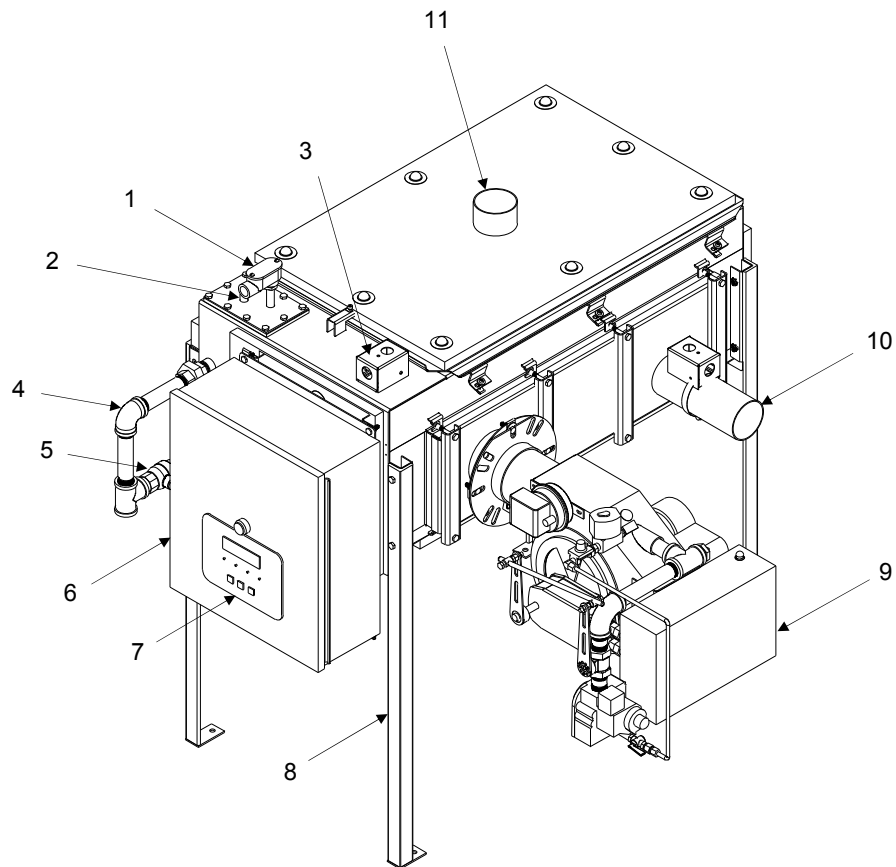

Features

- | | |
|--|-----------------------------|
| 1. Low Water Float Switch Junction Box | 7. INTAC® Microprocessor |
| 2. 1/4"-IPS Fill Inlet Connection | 8. Support Legs |
| 3. Over Temperature Cut-Out Switch | 9. Burner Assembly |
| 4. Flusher & Overflow Piping | 10. Exhaust Connection |
| 5. 3/4" Ball Valve | 11. Steam Outlet Connection |
| 6. Control Panel | |



Dimensions GXDDR-3 & GXDDR-4

Required Clearance:

For recommended service and maintenance purposes the following clearances should be maintained:

- Right side, see Top View for required clearance
- Front side, NEC requires 36" clearance to control cabinet
- Left side, 6" for access
- Rear, 6" for access
- Top, 12" for cover and float plate assembly removal

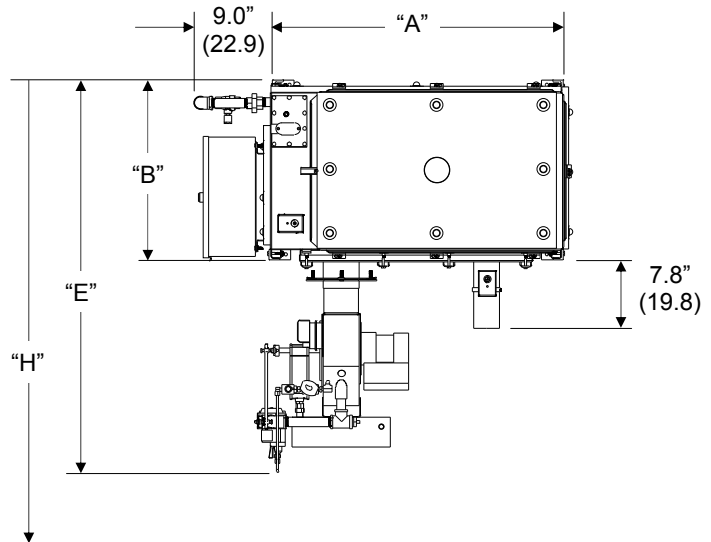

Top View

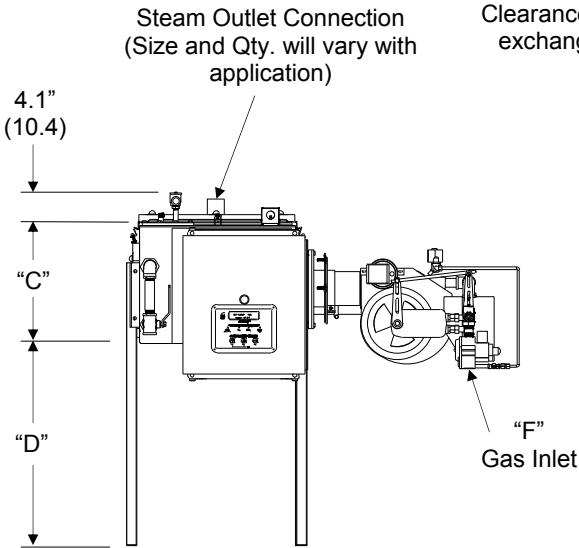

Front View

Clearance required for exchanger removal

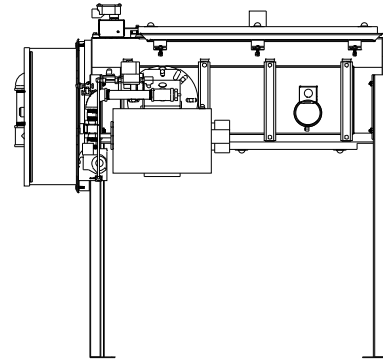

Right Side View

Unit Dimensions in Inches (cm)

Model No.	Dim. "A"	Dim. "B"	Dim. "C"	Dim. "D"	Dim. "E"	Dim. "F"	Dim. "G"	Dim. "H"
GXDDR-3	34.0" (86.4)	21.1" (53.7)	13.8" (34.9)	24.0" (60.9)	45.9" (116.5)	3/4"-NPT	3.0" (7.62)	50.0" (127.0)
GXDDR-4	54.0" (137.2)	30.1" (76.5)	13.8" (34.9)	24.0" (60.9)	54.7" (138.9)	3/4"-NPT	3.0" (7.62)	66" (167.6)

Heat exchangers have a top and bottom. There is a break (crease) on the bottom side of the heat exchanger. Do not install heat exchanger upside-down.

All dimensions are approximate and subject to change at manufacturer's discretion.



Dimensions GXDDR-8

Required Clearance:

For recommended service and maintenance purposes the following clearances should be maintained:

- Right side, see Top View for required clearance
- Front side, NEC requires 36" clearance to control cabinet
- Left side, 6" for access
- Rear, 6" for access
- Top, 17" for cover and float plate assembly removal

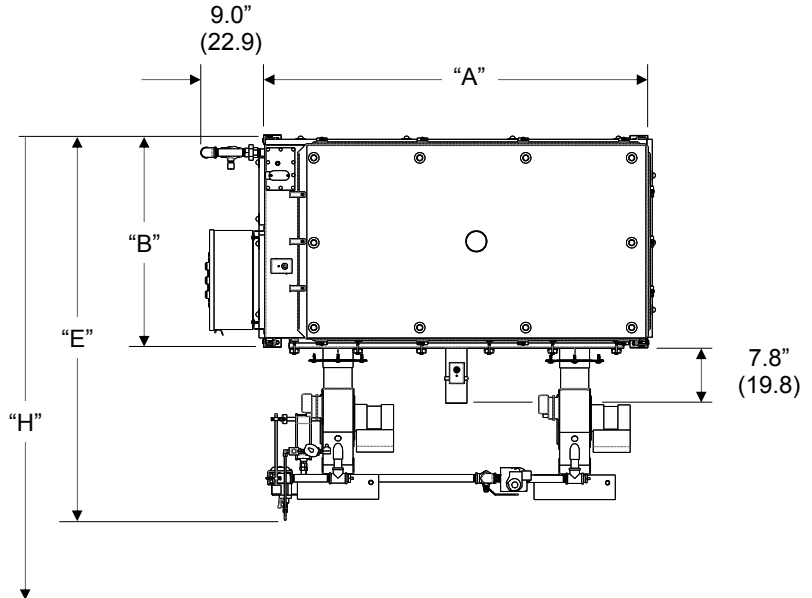

Top View

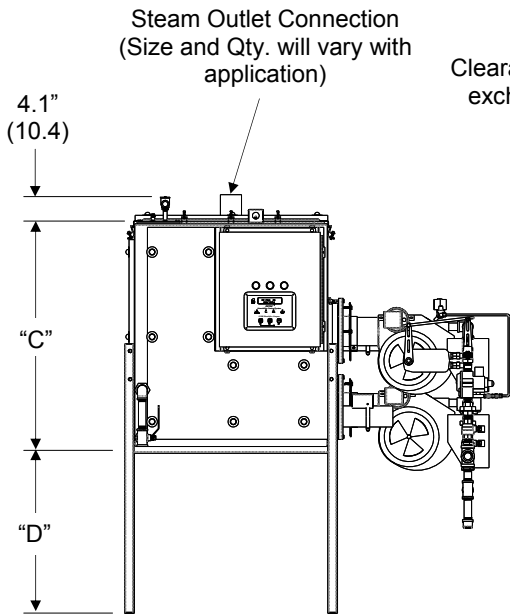

Front View

Clearance required for exchanger removal

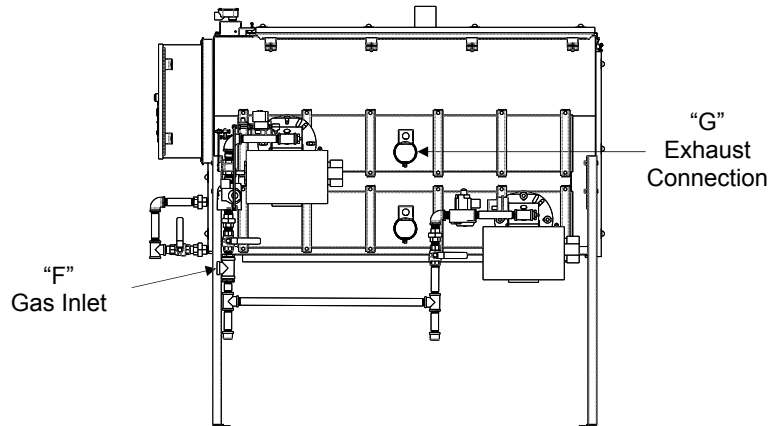

Right Side View

Unit Dimensions in Inches (cm)

Model No.	Dim. "A"	Dim. "B"	Dim. "C"	Dim. "D"	Dim. "E"	Dim. "F"	Dim. "G"	Dim. "H"
GXDDR-8	54.0" (137.2)	30.1" (76.5)	32.5" (82.6)	24.0" (60.9)	54.7" (138.9)	1"-NPT	3.0" (7.6)	66.0" (167.6)

Heat exchangers have a top and bottom. There is a break (crease) on the bottom side of the heat exchanger. Do not install heat exchanger upside-down.
All dimensions are approximate and subject to change at manufacturer's discretion.



Dimensions GXDDR-12

Required Clearance:

For recommended service and maintenance purposes the following clearances should be maintained:

Right side, see Top View for required clearance

Front side, NEC requires 36" clearance to control cabinet

Left side, 6" for access

Rear, 6" for access

Top, 17" for cover and float plate assembly removal

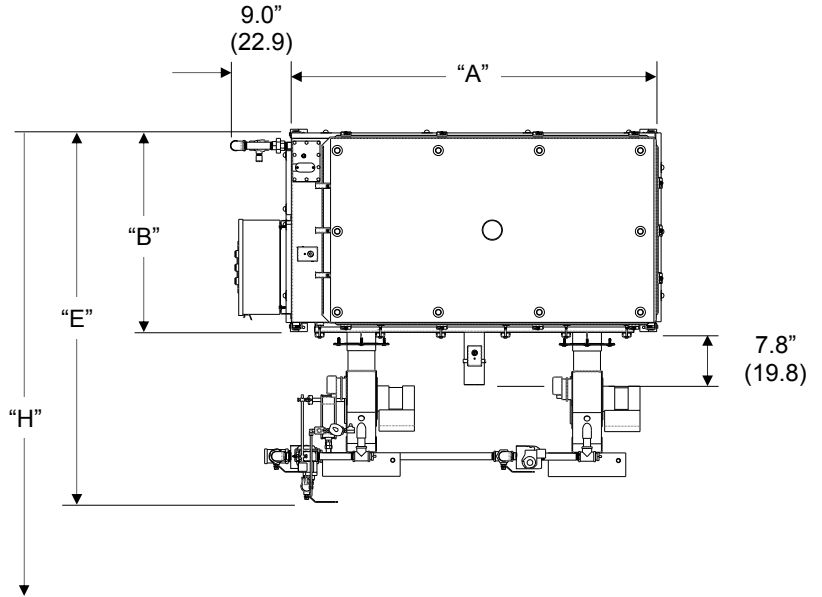

Top View

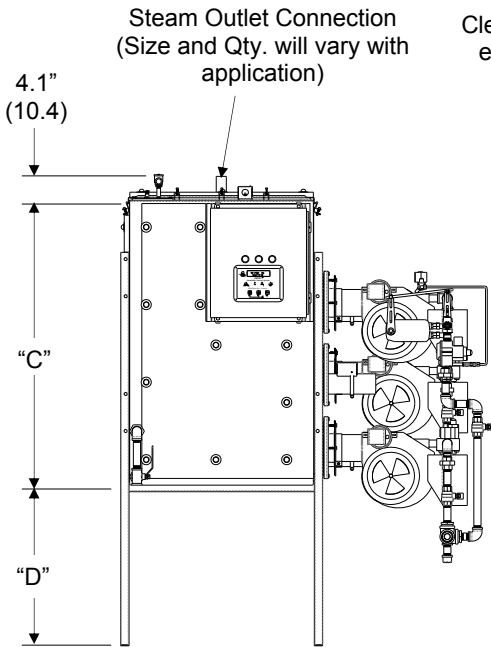

Front View

Clearance required for exchanger removal

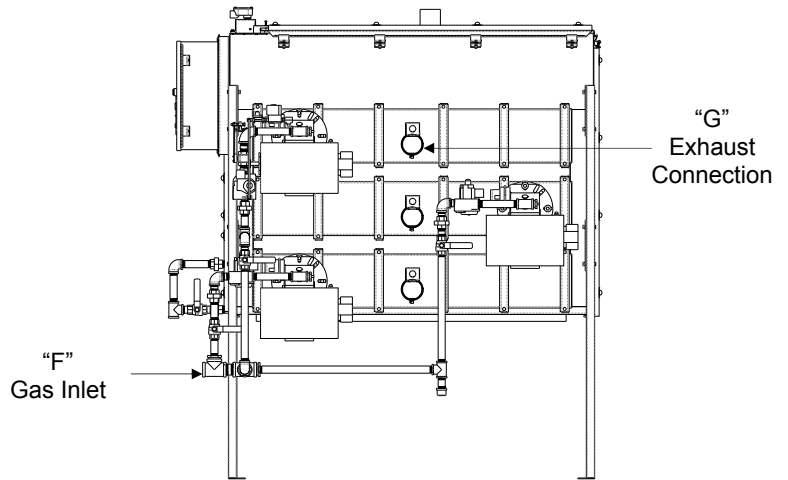

Right Side View

Unit Dimensions in Inches (cm)

Model No.	Dim. "A"	Dim. "B"	Dim. "C"	Dim. "D"	Dim. "E"	Dim. "F"	Dim. "G"	Dim. "H"
GXDDR-12	54.0" (137.2)	30.1" (76.5)	43.5" (110.5)	24.0" (60.9)	55.8" (141.1)	1-1/4"-NPT	3.0" (7.6)	66.0" (167.6)

Heat exchangers have a top and bottom. There is a break (crease) on the bottom side of the heat exchanger. Do not install heat exchanger upside-down.

All dimensions are approximate and subject to change at manufacturer's discretion.



Modulating Control Operation

Overview

The INTAC[®] will control up to 3 gas burners.

The INTAC[®] outputs are defined as:

Blower Output:	Heater Output #1
Burner #1 Enable:	Heater Output #2
Burner #2 Enable:	Heater Output #3
Burner #3 Enable:	Heater Output #4
Burner #1 Proportional Valve Control:	Analog Process Output

Setting	Models		
	GX-3 GX-4 GXDDR-3 GXDDR-4	GX-8 GXDDR-8	GX-12 GXDDR-12
710: Low Fire Set Pt	40%	20%	10%
711: Low Fire Hys	3%	3%	3%
712: Burner 2 Set Pt	NA	75%	50%
713: Burner 2 Hys	NA	3%	3%
714: Burner 3 Set Pt	NA	NA	75%
715: Burner 3 Hys	NA	NA	3%

Gas System Sequence

Items in parentheses are referring to an INTAC[®] menu number. Refer to INTAC[®] manual for more detail

1. When % Power (002) is greater than the Low Fire Set Point (710) , the Blower Output and the Burner #1 Enable Output will energize.
2. If configured for at least a two-burner system, when % Power (002) is greater than Burner #2 Set Point (712) Burner #2 Enable will turn on.
3. If configured for a three burner system when % Power (002) is greater than Burner #3 Set Point (714) Burner #3 Enable will turn on.
4. The Analog Process Output is the value determined by the % Power (002) and the number of burners installed. The Analog Process Output is wired to Burner #1 modulating actuator which is mechanically connected to the gas butterfly valve and the air damper. With more than one burner, the process output is multiplied to reflect that Burner #1 is only controlling 1/2 or 1/3 of total system output power.



Modulating Control Operation (cont'd)

% Power	Process Output Value (0-10 vdc)		
(screen 002)	One Burner	Two Burners	Three Burners
0	0 vdc	0 vdc	0 vdc
10	1 vdc	2 vdc	3 vdc
20	2 vdc	4 vdc	6 vdc
30	3 vdc	6 vdc	9 vdc
40	4 vdc	8 vdc	10 vdc
50	5 vdc	10 vdc	10 vdc
60	6 vdc	10 vdc	10 vdc
70	7 vdc	10 vdc	10 vdc
80	8 vdc	10 vdc	10 vdc
90	9 vdc	10 vdc	10 vdc
100	10 vdc	10 vdc	10 vdc

5. When % Power is less than Burner #3 Set Point (714) minus Burner 3 Hysteresis (715), Burner #3 Enable output turns off.
6. When % Power (002) is less than Burner 2 Set Point (712) minus Burner 2 Hysteresis (713), Burner #2 Enable output turns off.
7. When % Power (002) is less than the Low Fire Set Point(710) minus the Low Fire Hysteresis (711) Burner #1 Enable turns off. The blower output will remain on for the Post Purge Timer (716) time. If the % Power increases to a value greater than the Low Fire Set Point (710) during the Post Purge time, the Blower Output will remain on and the sequence will begin again (only after the Post Purge Timer (716) has timed out).
8. Burner #2 can only turn on if Burner #1 is on.
9. Burner #3 can only turn on if Burner #2 is on.
10. If the % Power (002) is equal to zero all burners will be off.
11. Once a burner is enabled and the burner airflow switch is proven, that burner's flame controller will get power. The flame controller will run its own 30 second pre-purge before attempting to light the pilot and energize the main gas valve.
12. Burner #1 also has an end switch on the modulating motor that will close when the air damper is in the high-fire position. The Burner #1 flame controller will initially receive power when the Burner #1 enable relay is closed, its airflow switch is closed and the end switch on the modulation motor is closed.



“GXDDR” Prestart-Up Procedure

Pre-Startup Checklist

Before starting the “GXDDR” PURE Humidifier Co. Gas Fired Humidifier, check the following installation items:

- _____ 1. MOUNTING - Verify that the humidifier evaporating chamber is securely supported and that the evaporating chamber is level in both directions. If humidifier is installed above equipment or not located near a floor drain than a drain pan should be installed below the humidifier steam generator.
 - _____ 2. INJECTION TUBE - Verify that the humidifier injection tube is mounted within the duct with the proper pitch back to the humidifier (2”/5 cm per foot / 31 cm). NOTE: If the humidifier evaporating chamber or the flexible hose (optional) is mounted higher than the injection tube, a drain “tee” is required to drain the condensate out of the injection tube steam line. If it is an Insty-Pac or Fast Pac refer to the respective O&M to determine if they are mounted properly and have the proper p-trap size.
 - _____ 3. ELECTRICAL - Verify that all wiring connections have been connected in accordance with the wiring diagram. **CAUTION: Live power may exist in the control cabinet. Turn off the main power at the disconnect switch before verifying the electrical connections!**
 - _____ 4. SAFETY CONTROLS – The supply air duct RH high-limit should be installed at least ten feet downstream from the humidifier tube(s). Any other control sensors should be at least 10 feet downstream from the humidifier tube (s). Smoke detectors should not be installed downstream of the humidifier tube(s). If a smoke detector absolutely has to be installed downstream from the humidifier tubes then it should be installed as far from the tubes as possible.
 - _____ 5. PIPING: Water Supply - Verify that all piping connections have been completed as recommended and that water pressure is available to the humidifier. Verify that the supply water pressure is 35-50 psi. There should be at least 5 ft of metal pipe and check valve between the tank and any plastic pipe.
- REMOVE INTERNAL PACKING MATERIAL FROM AROUND THE FLOAT BALL ASSEMBLY BEFORE STARTING UNIT. FAILURE TO DO SO CAN RESULT IN THE OVER-HEATING OF THE HUMIDIFIER AND POTENTIAL FIRE.**
- _____ 6. PIPING: Drain - Make sure a water seal of the proper height (refer to steam generator O&M for height) is provided in the drain line.
 - _____ 7. PIPING: Gas - Make sure a field installed main shut-off is installed before the humidifier burner/gas train. Make sure a union is installed after the main shut-off. Make sure the supply pressure to the humidifier matches the name plate value.
 - _____ 8. PIPING: Steam Outlet - Refer to page 14 for proper outlet steam piping from the generator to the tube(s). **Any horizontal to vertical up transition in the outlet steam pipe requires a water-sealed drip leg!** Improper outlet steam piping will cause steam to leak from the steam generator. Runs over 20 ft long may require upsizing of the steam pipe.
 - _____ 9. EXHAUST VENTING: Measure the exhaust vent diameter. See page 15 for the vent size chart. Measure the exhaust vent diameter. A drain tee should be installed at any low point in the exhaust.

Signature: _____ Date: _____



“GXDDR” Start-Up Procedure

Introduction

The burner should be initially set up and serviced at regular intervals (preferably at the beginning of and mid-way through high use period) by a trained serviceman using the proper test instruments.

Start Up Procedure

- _____ 1. Make sure the electric power is shut off to the humidifier.
- _____ 2. Close the humidifier manual ball valve (located on the left side of the humidifier evaporating chamber faceplate).
- _____ 3. Open the water supply on/off control valve and allow the humidifier evaporating chamber to fill to the proper level.
- _____ 4. After the humidifier is full of water, turn on the main power to the control cabinet.
- _____ 5. Verify the low water safety switch by closing the water supply, opening the drain valve and verifying that the low voltage relay within the control cabinet “pulls-out” when the water level is dropped below the low water shut off switch (you can hear the relay switch “out”).
- _____ 6. Close the drain valve, open the water supply valve, and allow the humidifier to fill to the proper level. Allow the tank to fill completely and make sure that the make-up water float valve shuts off completely and does not over flow the tank before proceeding.
- _____ 7. Make sure all the optional safety switches are satisfied (air-flow proving switch, high-limit humidistat, etc.).
- _____ 8. Proceed to "Burner Start Up Procedure".
- _____ 9. Check operation of field installed safety switches (air flow proving switch, high-limit humidistat, etc.) to make sure they turn the power off to the pilot relay which is the control circuit power. The safety switches should shut off the humidifier burner(s) whenever one or more of the optional safety switches create an open circuit.
- _____ 10. Inspect installation for leaks by operating humidifier at a full, rolling boil. This may take up to 15 minutes from a cold start. Any leaks should be sealed. Just tightening a pressure clamp will not work if the gasket is not properly positioned between the sealing surfaces. If necessary, remove the cover or side-entry plate, reseal gasket and replace cover or side entry plate. A small amount of adhesive (super glue, gorilla glue, spray adhesive, etc.) to hold the gasket in place while repositioning the cover or side-entry plate will aid in this process.
- _____ 11. After the unit is producing steam, check and retighten all hose clamp connections in the system and make sure they are torqued to 35 -40 in-lbs.

Signature: _____ Date: _____



“GXDDR” Burner Start-Up Procedure

Burner Start-Up Procedure:

The following procedure may be used by qualified service personnel to start the GXDDR series gas humidifier. It is assumed that all electrical, gas supply and exhaust systems have been installed by qualified professionals per all applicable codes and regulations and have been tested and accepted.

Equipment Needed:

1. Gas Analyzer
2. DC-Microamp meter (Range 0 to 200 microamps)
3. 2 Manometers (Range 0 to 20 inches WC)
4. 3/4” NPT to 1/8” NPT Hex Reducer

Before Starting:

- _____ 1. Verify that the “TYPE” of fuel is correct for the specific orifice installed (Natural Gas or LP Gas).
- _____ 2. **Verify that the MAIN SUPPLY gas pressure is correct.** This should be taken at the 1/8” NPT pressure tap on the manual shut-off valve immediately upstream of burner gas train. Use one of the manometers to see that it is **7 inches W.C. for natural gas, 10 inches W.C. for propane.** If the gas pressure is not correct, adjust the regulator feeding the humidifier. If this cannot be done the burner regulator and pilot will require adjustments.
- _____ 3. Verify that the electrical supply voltage is correct.
- _____ 4. Verify that the exhaust system is installed and is not blocked.
- _____ 5. Verify that the gas train piping on the burner is plumb and square. Piping may have shifted during shipment so check to make sure all gas connections are tight.
- _____ 6. Check the air damper/gas butterfly valve linkage markings. Make sure all markings are aligned.

- _____ 7. Using the 3/4” to 1/8” hex reducer, remove the 3/4” plug and **hook up the second manometer to the orifice tee downstream of the combination valve, butterfly modulating valve and/or orifice if one is installed.** This is where manifold pressure will be measured.

Start-Up and Adjustments:

- _____ 1. The air damper will be fully open if the burner is to be fired at the maximum rate. Otherwise, depending upon the desired output, the air damper will be in an intermediate position during start-up.
- _____ 2. Turn Gas Combination Valve to “Off” position.
- _____ 3. Install a dc-microamp meter in series with the Flame Safeguard “Sense” line.
- _____ 4. Start burner sequence by changing the RH set point to 100% RH in the INTAC® menu 101. The INTAC® controller should call for 100% output on menu 002 at this point. If the humidifier is being controlled by a building management signal, have the controller call for an input of 10 VDC or 20 mA, which ever is applicable. If it is controlled by an on/off humidistat, set the humidistat to 100% RH.
- _____ 5. After automatic 30-second purge cycle, pilot ignition will begin. You will hear the pilot solenoid “click” open. At this time, while the “pilot” light is lit, slowly adjust the pilot regulator and adjust until a maximum flame current is achieved (approximately 1.5 microamps or higher). Repeat the process until pilot lights every time burner is started.
- _____ 6. Typically the pilot regulator will be about 2 full rotations out from the “bottom” fully tightened position. The red button on the front of humidifier control panel will reset the burner automatically if the pilot fails to light.
- _____ 7. With pilot ignited, turn the Combination Regulator Valve to “On” position.



“GXDDR” Burner Start-Up

- _____ 8. Adjust the main burner combination regulator to give a manifold pressure equal to what is specified on the humidifier nameplate. **Manifold pressure measurement should be made at the 3/4” orifice tee after the orifice if one is in stalled.** After making a pressure adjustment, allow approximately one minute for the system to find a steady value. (Note: Excessive gas pressure may cause burner to “rumble” or a slight backfire may result. If this occurs, back off the main burner gas pressure slightly until the rumble is not noticeable).
- _____ 9. Allow humidifier to warm-up. This may take up to half an hour. After humidifier has warmed-up, recheck the manifold pressure while the unit is still calling for 100% power on menu 002 on the INTAC® display.
- _____ 10. Observe the O2 (Excess Oxygen) level. Should be approximately 3 to 7 percent.
- _____ 11. Observe the CO (Carbon monoxide) level. Should be under 100ppm.
- _____ 12. Observe the flame current is reading slightly higher. (Approximately 3 microamps or higher.)
- _____ 13. If the unit has a modulating burner proceed to the “For Modulating Burner Section”
- _____ 14. If you have an on/off control, reset RH set point to the proper humidity level or return building management to normal operation. Replace 3/4” plug. Make sure orifice is seated properly and the spring installed. Apply quality pipe compound to the 3/4 plug threads and screw it back into place.

For Modulating Burners

Burners set up for modulation are tuned in the factory. However, due to different conditions that occur with each particular installation, slight adjustments may have to be made with the gas/air linkage.

Consult the factory before making adjustments to the linkage.

Once it has been verified that the burner is operating at acceptable levels at high fire, low fire operation should be checked. Make sure that burners two and three are off as well as the manual gas valves. To check the burner’s combustion at low fire change the process output setting on INTAC® menu 519 to 3 volts.

Allow the burner to modulate down and let the gas analyzer readings to stabilize. The readings should be as specified in steps 10-12 of the “Start up and Adjustments” section. If the readings are acceptable then change the process output setting on INTAC® menu 519 back to 10 volts. If they are not acceptable or if the burner blows itself out while modulating down, the burner linkage will need adjustment. After adjustments are made, change the INTAC® menu settings back to their original values.

For Multiple Burner Humidifiers

For two and three burner models, only the first burner modulates. The additional burner(s) are of the on/off type. The modulating burner should be checked first. Turn off the manual gas valves to the other burner(s). Proceed with the steps above.

Once the first burner is operating properly proceed with the next burner. Once all burners are operating, recheck the manifold pressures for each of the burners. Also check that the supply pressure has not dropped and is steady.

Return INTAC® settings on menus 101 to the desired humidity set-point or return building management signal back to automatic operation mode.

Signature: _____ Date: _____



Tool Requirements & Torque List

Recommended Maintenance Tool List
7/16" Wrench
3/4" Wrench
Crescent Wrench
11/32" Nut Driver or Socket
3/8" Nut Driver or Socket
5/32" Allen Head
Flat Head Screwdriver
Wire Stripper
Wire Crimper

Torque List	
Cover Bolts	18 inch/pounds MAX
Side Entry Exchanger Bolts	80 inch/pounds MAX
Hose Cuff Screws	35-40 inch/pounds MAX when hot



“GXDDR” Trouble Shooting

<u>Problem</u>	<u>Possible Cause</u>	<u>Recommended Action</u>
Humidifier will not heat	Blown control fuse	Check and replace
	Control transformer not producing 24 vac control voltage	Check transformer output. Verify voltage across terminals J5 #5 and J5 #7
	Safety controls open (air-flow switch, high-limit, etc.)	Verify that all safety controls are completing the safety circuit
	Overtemp protection switch tripped	Indicates the humidifier is running while low on water. The level control circuit has interference or is damaged. Tri-probe wires should be run separate from power wiring. Do not reset the switch until the source of the problem is identified and corrected. Consult factory if you are unsure of the source of the problem.
Humidifier will not fill	Faulty humidity sensor	Verify voltage to and from humidity sensor
	No water pressure	Check water supply
	Drain valve open	Close drain ball valve
Humidifier does not stop filling or is short cycling	Faulty water float valve	Check float valve seat for dirt
	Float valve stuck open	Check float valve seat for dirt Adjust float ball arm
Humidifier says water is low but is hot filling	Drain valve open	Close drain valve
	Low water pressure	Adjust float valve arm upward to allow water to fill high enough above low water cut out switch



“GXDDR” Maintenance

PURE Humidifier Co. “GXDDR” Maintenance Instructions

The “GXDDR” Series Humidifier is designed to provide the best possible operation with minimum maintenance. However, the humidifier should be inspected and placed on a dedicated maintenance schedule to ensure continued operation of the humidifier and accessories. **PURE Humidifier Co. recommends that the following items be inspected and/or cleaned on a minimum basis of twice each year.** If excessive mineral build-up occurs, the maintenance schedule should be increased.

Inspect / Maintenance Item

Procedure to Follow

Water Make-Up Float Valve

Check to make sure the fill valve is operating properly. If the valve appears to continually fill, check the valve seat and seal (see trouble shooting instructions).

Low Water Float Switch

Check to make sure the switch will shut the humidifier off when the water level drops too low. Close the water supply and open the drain valve to allow water to drain out for checking. Make sure to reset the drain valve after inspection is completed.

Safety Interlocks
(air-flow, high-limit)

Check to make sure the safety interlocks (air-flow, high-limit, etc.) will shut down the humidifier.

Combustion Burners

Inspect and clean flame rod. Inspect air intake for obstructions and clean as required. Burner gas valve has an expected life of 200,000 cycles. Replace the valve at the end of the life cycle.

Humidifier Cover / Tank

Inspect for any leaks. Repair as required. Remove the mineral deposits from floor of the humidifier reservoir. If excessive build-up is found, the cover may need to be removed to facilitate complete cleaning of the humidifier.

Flexible Hose

Inspect for cracks or leaks. It is normal for the hose to become hard and develop a “set”.

Cleaning Instructions

All humidifier tanks should be cleaned manually from the side-entry plate or cover. Remove all loose solids with a wet vacuum or putty knife and bucket. Exchanger should also be cleaned and loose build-up removed by hand (if applicable). After removal of solids and replacing the heat exchanger, you may wish to add a de-scaling solution. Heat exchangers have a top and bottom. There is a break (crease) on the bottom side of the heat exchanger. Do not install heat exchanger upside-down. **DO NOT** use Hydrochloric acid-based de-scalers; this will corrode stainless steel. PURE Humidifier Co. recommends the use of a vinegar, citric acid, diluted phosphoric acid, or diluted nitric acid-based cleaner. Follow all precautions on the cleaner packaging. Some cleaners will give off overwhelming and noxious odors, so make sure there is proper ventilation in the working area and the cover is removed so that fumes are not spread throughout the building. After cleaning the tank, flush the tank multiple times to remove any remaining acid. Drain tank completely and allow the tank to air dry for a few hours. This will ensure that the outer protective layer of the stainless steel will passivate and ensure corrosion resistance.



Burner Troubleshooting & Maintenance

Service/Maintenance Suggestions

The burner should be initially set up and serviced at regular intervals (preferably at the beginning of and mid-way through high use period) by a trained serviceman using the proper test instruments.

There is a red reset button/main gas light on the front of the humidifier control panel for each burner. Depressing the button will restart that particular burner's operation. If the pilot valve opens and the main gas light does not come on, the button must be depressed to reset the burner lockout. During start-up this may have to be repeated several times to purge air from the gas line. If the main gas light turns on briefly, then the burner controller will retry automatically after a short time delay.

Burner Fails to Start:

1. Bad fuse or switch open on incoming power source, or motor overload out.
2. Control circuit has an open control such as operating, limit or low water cut-off.
3. Push the reset button on the motor or open the power circuit on the the primary safety control.
4. Loose or faulty wiring. Tighten all terminal screws. Check wiring against wiring diagram furnished with burner.

Burner Motor Runs, But Pilot Does Not Light:

1. Be sure gas is turned on at meter and pilot cock is open.
2. Place hand on pilot valve to "feel" it open. Check gauge at tee in pilot line for gas pressure and prompt opening of pilot valve.
3. Check visually or by sound for spark arcing.
4. Refer to pilot checking procedures.
5. Check air switch and be sure its circuit closes during start.

Burner Motor Runs, Pilot Lights But Main Gas Valve Does Not Open:

1. Burner not enabled by INTAC[®]
2. Check flame signal. If signal is low, adjust pilot gas pressure and air settings for improved readings.
3. Check gas valve circuit.
4. Shut-off cock or test cock not open.
5. Defective main valve.

Occasional Lockouts For No Apparent Reason:

1. Look for large gas pressure fluctuations. Stabilize pressure.
2. Re-check microamp readings. If insufficient, check gas pressure and air damper setting. Check electrode setting. If flame signal is low, flame rod may have to be re-positioned.
3. Check ignition cable and electrode porcelain for damage or breaks, which could cause short.
4. Check for loose or broken wires.
5. Read flame monitor lockout code and and follow flame monitor directions.

Burner Will Not Start—Even Though Burner Had Never Failed Before or Had Been Running On Normal Cycling Without Failure:

1. Operating control circuit open.
2. Defective control or loose wiring.
3. Limit circuit open.

The burner must be periodically inspected to insure safety and performance. All maintenance must be performed with the main electrical power off and the main gas shut-off valve off.

1. Inspect blower inlet screen and clean any buildup of lint.
2. Inspect blower wheel blades and clean any buildup of dirt.
3. Inspect ignition electrodes and wiring for any cracks that may cause shorting.
4. Oil the blower motor at the manufacturer's recommended intervals.
5. Verify that the pilot and or direct spark electrodes are still within specifications (set per drawing in this manual).
6. Verify the proper operation of the Primary Safety Control, airflow switch, and operating controls.
7. Check safety gas shut-off valves for gas tightness.

In the event of extended shutdown, the main power should be turned off and the main manual gas shut-off valve should be closed.

EMERGENCY SHUTDOWN: WARNING: Should over-heating occur: (1) shut-off manual gas valve(s) to the humidifier, (2) allow humidifier to cool, (3) check the heat exchanger(s) and remove excessive mineral build-up, (4) make sure the exhaust vent is not blocked with foreign material. After the required maintenance has been performed, the manual over-temp reset button on the exhaust and/or on the tank must be depressed.

An additional source of information relative to troubleshooting can be found in the Flame Safeguard Control Manual supplied with the burner.

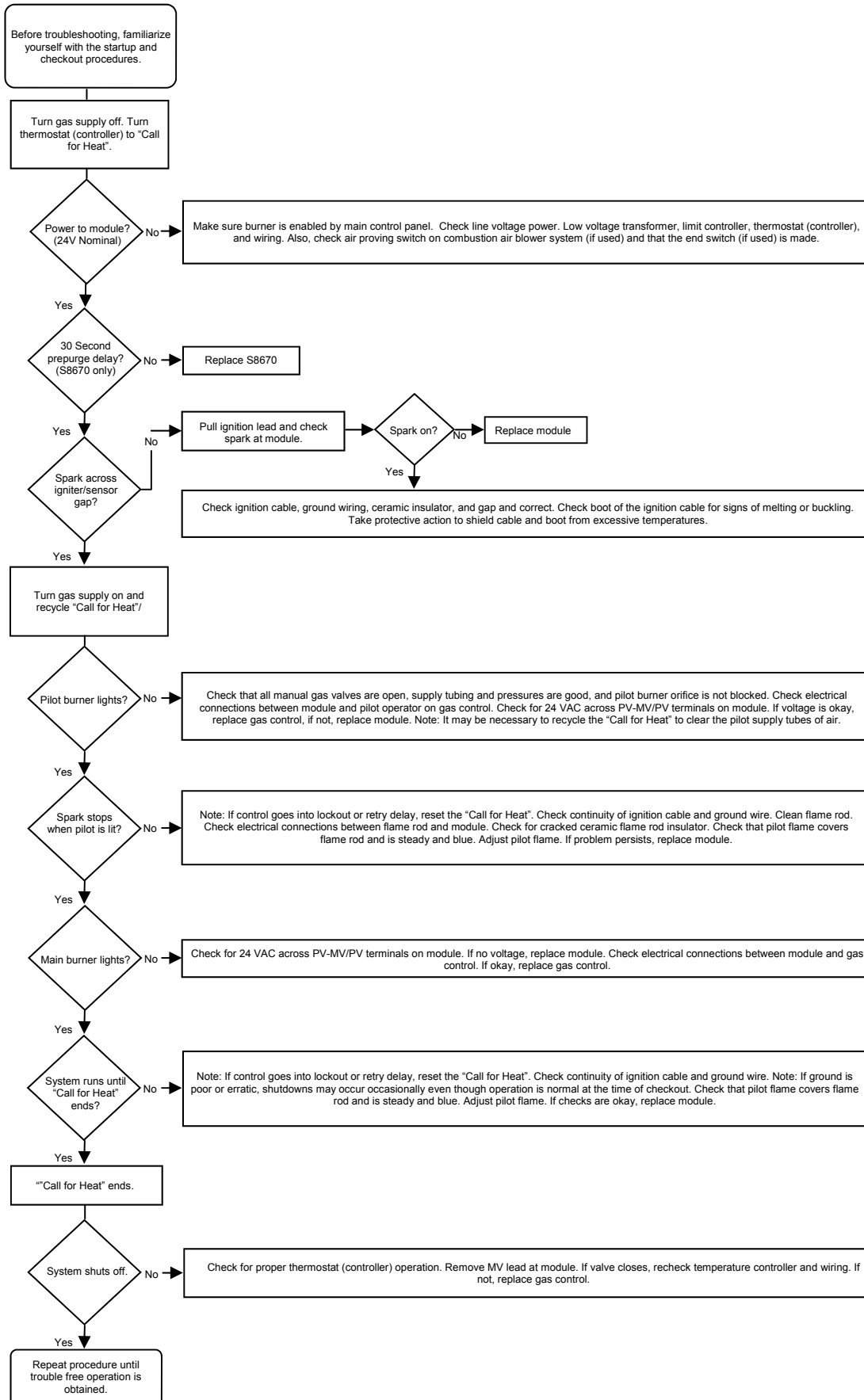



Exchanger Gasket Replacement Instructions

WARNING

Disconnect the humidifier power, gas, exhaust system and allow the humidifier to cool prior to servicing. Drain water level below the level of the exchanger being serviced. Heat exchangers have a top and bottom. There is a break (crease) on the bottom side of the heat exchanger. Do not install heat exchanger upside-down

- Loosen the exchanger cover clamp screws with a 7/16" socket wrench until the locknuts can be slid out from the mounting clamps. Repeat this step for all clamps. Remove exchanger.
- Remove the old gasket and adhesive left of the heat exchanger. Make sure this surface is clean, dry, and free of oil, grease or water. Turpentine may be used to clean the surface areas.
- Spray contact adhesive such as 3M product Super 77 on one side of the new gasket and on the exchanger surface where the gasket is to be applied. Allow both surfaces to dry a minimum of one minute or until the surfaces become tacky to assure proper bonding.
- Square one end of the new gasket on one end of the exchanger and set by applying light to moderate pressure to the gasket. Square the other end of the gasket on the other end of the exchanger. It is common for the gasket to appear too long. Now slowly start setting the gasket from the ends towards the middle of the exchanger. A slight compression of the gasket will occur ensuring proper fit on the ends.
- Apply moderate to heavy pressure on the newly installed gasket all the way around ensuring proper fit. A properly installed gasket will lay flat with no raised areas.
- Reinstall the heat exchanger into the humidifier.
- Loosely install all of the exchanger cover clamps.
- Using a 7/16" torque wrench set at 60 inch/pounds tighten all clamp screws.
- In a reverse manner, reconnect all gas, exhaust and electrical connections. Fill humidifier with water and check for leaks.
- Observe for leaks and tighten slightly if a leak area is found. DO NOT EXCEED 120 inch/pounds.



Cover Gasket Replacement Instructions

Remove the reservoir cover. While looking at the top of the unit, reference Figure A and B to determine which humidifier tank style you have.

Figure A Installation

Fit the gasket around the entire lip of the tank opening. Cut the gasket 1/8" longer than required, this will ensure proper fit when the cover is clamped back on. Slide the gasket onto lip of tank around the entire perimeter, and seal the ends together with a small amount of silicone.

Figure B Installation

Fit the gasket around the entire lip of the tank opening. Cut the gasket 1/8" longer than required, this will ensure proper fit when the cover is clamped back on. Slide the gasket onto lip of tank around the entire perimeter. Notch only the bottom flap of the gasket (reference Fig. C) in the corners of the tank. Seal the ends together with a small amount of silicone.

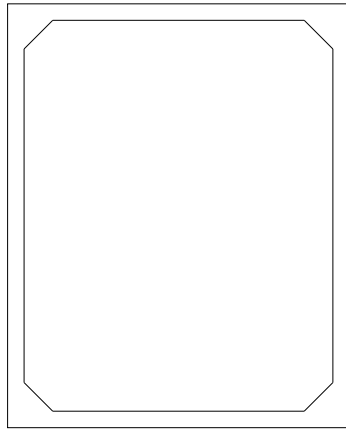

Fig. A
Plan View of Humidifier

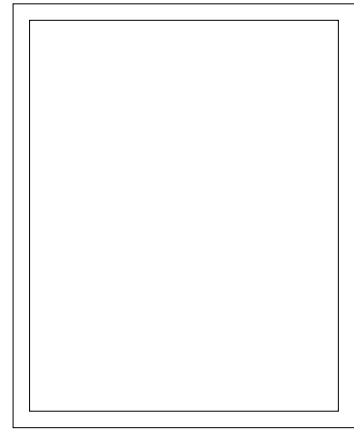
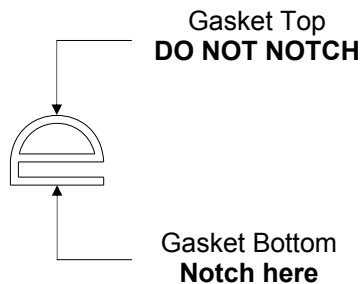
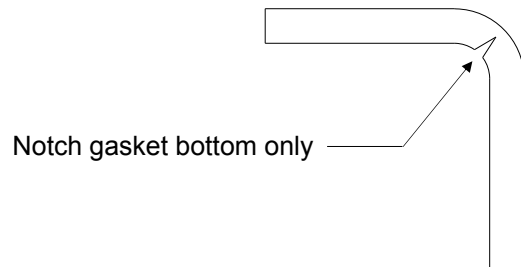

Fig. B
Plan View of Humidifier



Section View of Gasket



Bottom View of Gasket

Fig. C

NEMA-12 HUMIDIFIER CONTROL CABINET
WITH DOOR OPEN

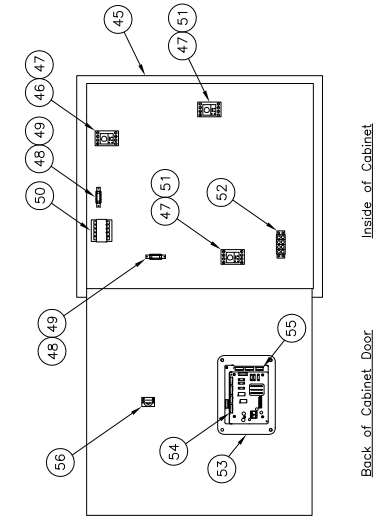

Inside of Cabinet

Back of Cabinet Door

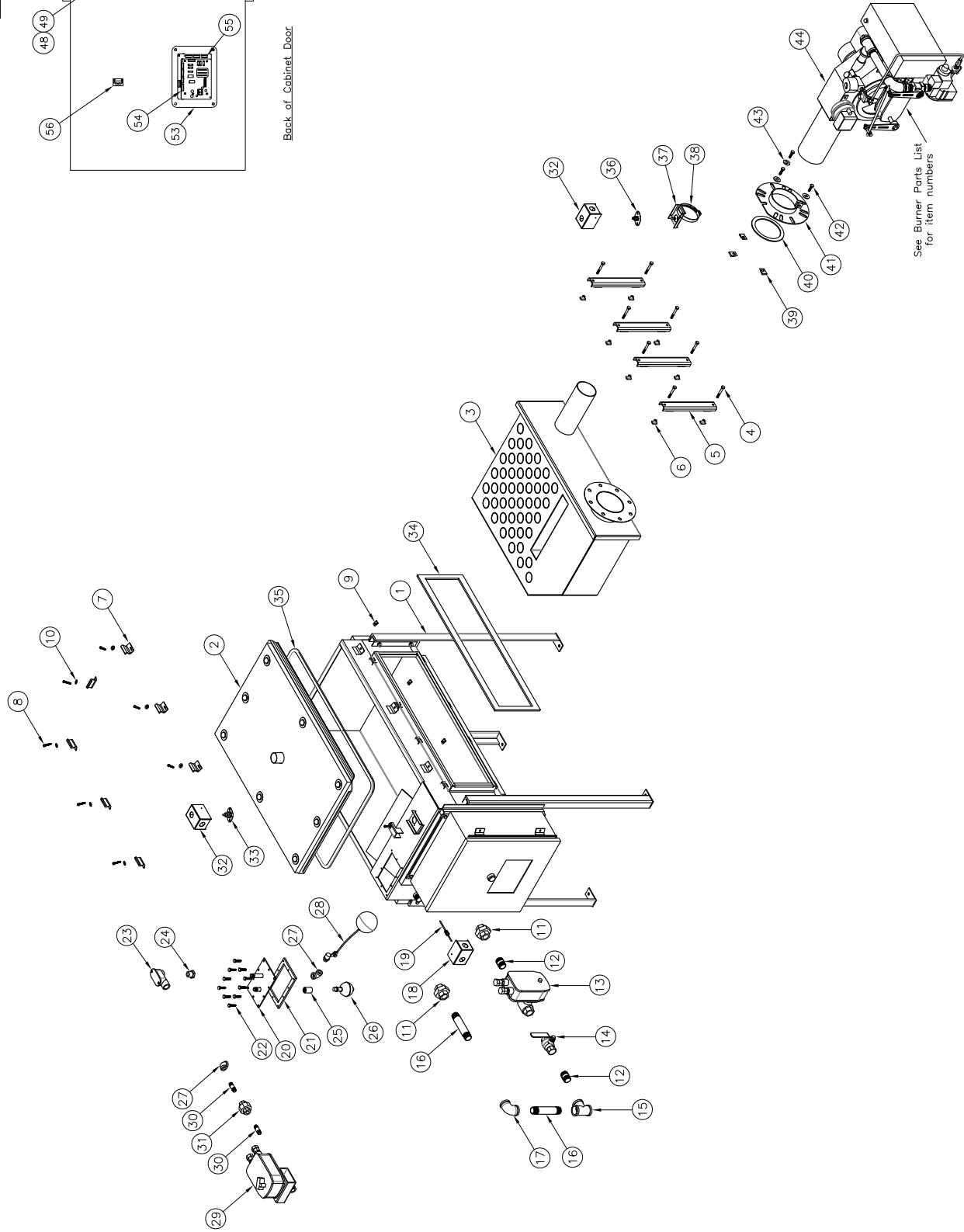

See Burner Parts List
for item numbers



Title: GXDDR-3 & GXDDR-4 EXPLODED ASSEMBLY		Dwg No: GXDDR-3 EXPLODED ASSEMBLY
Scale: No Scale	Date: June 10, 2013	Drwn: J.M.R.

PURE Humidifier Co. "GXDDR-3 and GXDDR-4"
Parts List & Two Year Recommended Spare Parts

Item No.	Description	Part No.	Qty Per Unit	Rec. SpareQty
1	GXDDR Tank Assembly	A	1	
2	GXDDR Tank Cover Assembly	A	1	
3	GX Heat Exchanger Assembly	A	1	
4	U-Clamp Bolts 1/4-20 x 2 Zinc Hex	15841	A	
5	U-Clamp Bar Assembly	99136	A	
6	1/4"-20 Weld Nut	15702	A	
7	Cover Clamp	15930	A	
8	Cover Clamp Screws	15522	A	
9	10-24 U-Nut	15524	A	
10	#12 SAE Zinc Washer	n/a	A	
11	3/4" Union Stainless Steel	07114	2	
12	3/4" x 1 1/2" Nipple Stainless Steel	07081	2	
13	3/4" Motorized Drain Valve Stainless Steel	09117	1*	
14	3/4" Ball Valve 316 Stainless Steel	09036	1	
15	3/4" Tee Stainless Steel	07115	1	
16	3/4" x 5" Nipple Stainless Steel	07011	2	
17	3/4" 90° Elbow Stainless Steel	07112	1	
18	Thermocouple Housing - Plain	16071	1*	
19	Type K Thermocouple	15853	1*	
20	DDR Float Plate Assembly	99134	1	
21	DDR Float Plate Gasket	05052	1	
22	10-32 x 3/4" Hex Bolt	15523	10	
23	1/2" Type LB Conduit Body	15079	1	
24	1/4" x 1/2" Hex Reducer	15694	1	
25	1/4" Coupling 304 SST	07001	1	
26	Low Water Float Switch	15048	1	
27	1/4" 90 Elbow 304 Stainless Steel	07002	1/2 *	
28	Water Fill Float Valve and Ball 316 Stainless Steel	09030	1	
29	1/2" Motorized Ball Valve Stainless Steel	09120	1*	
30	1/4" x 1 1/2" Nipple Stainless Steel	07043	2*	
31	1/4" Union Stainless Steel	07189	1*	
32	Overtemp Switch Housing	15072	2	
33	Overtemp Protection Switch	15047	1	
34	Heat Exchanger Gasket	A	1	
35	Cover Gasket	15520	1	
36	Exhaust Over Temperature Switch 450°F Manual Reset	21022	1	
37	Overtemp Switch Plate	99170	1	
38	3" Hose Clamp	15606	1	
39	3/8-16 J Nut	15850	3	
40	Burner Flange Gasket	05901	1	
41	Burner Flange	21072	1	
42	3/8-16 x 1 Hex Bolt	15943	3	
43	3/8 Stainless steel washer	15945	3	
44	Modulating Gas Fired Burner - See Burner Assembly Parts List	A	1	
45	Control Enclosure	12003	1	
46	Time Delay On Relay	12022	1	
47	Relay Base	12020	3	
48	2 amp Fuse	12063	2	
49	Fuse Holder	12085	2	
50	Step-Down Transformer	12160	1	
51	Finder Relay	12018	2	
52	4 Point Terminal Strip	12045	1	
53	INTAC [®] Microprocessor	12312	1	
54	7 Pin Terminal Connector	12310	4	
55	6 Pin Terminal Connector	12309	5	
56	Push Button Light with NC Relay	21021	1	

NOTES/CODES:

A = Part Number and quantity vary with model number.

* Optional feature that may not be on all equipment

When ordering replacement or spare parts please have Model and Serial numbers.

8/6/2013

NEMA-12 HUMIDIFIER CONTROL CABINET
WITH DOOR OPEN

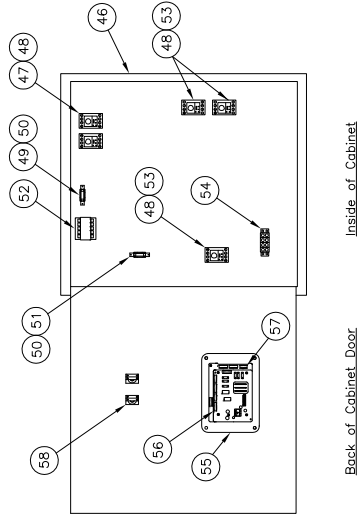

Inside of Cabinet

Back of Cabinet Door

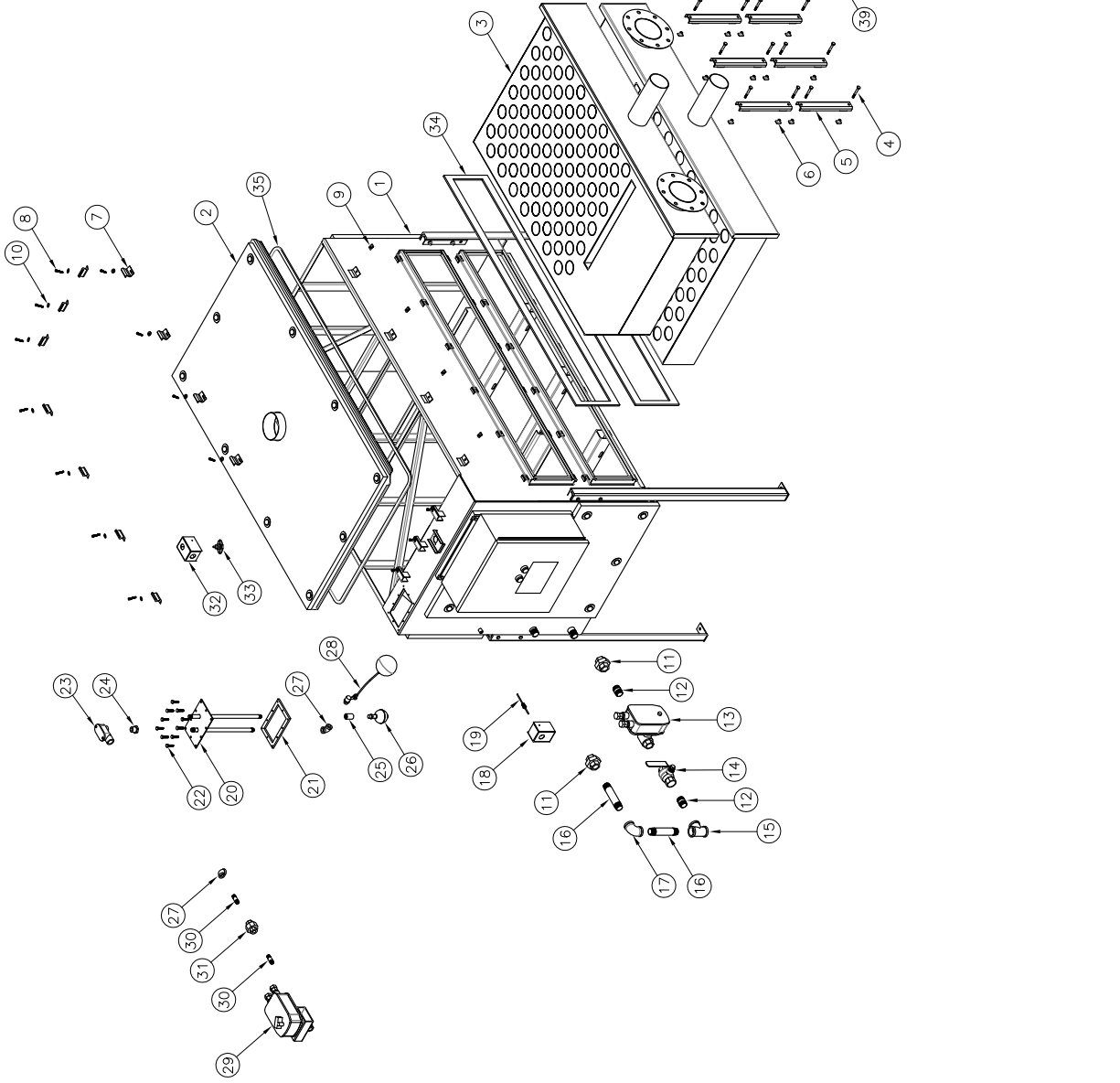

Title: GXDDR-8 EXPLODED ASSEMBLY		Dwg No: GXDDR-8 EXPLODED ASSEMBLY	
Scale: No Scale	Date: April 30, 2013	Drwn: S.A.M.	

**PURE Humidifier Co. "GXDDR-8"
Parts List & Two Year Recommended Spare Parts**

Item No.	Description	Part No.	Qty Per Unit	Rec. SpareQty
1	GXDDR-8 Reservoir Assembly	10025	1	
2	GXDDR-8 Reservoir Cover Assembly	99087	1	
3	GX-4 Heat Exchanger Assembly	A	2	
4	U-Clamp Bolts 1/4-20 x 2 Zinc Hex	15841	24	
5	U-Clamp Bar Assembly	99136	12	
6	1/4"-20 Weld Nut	15702	24	
7	Cover Clamp	15930	11	
8	Cover Clamp Screws 10-24 hex socket	15522	14	
9	10-24 U-Nut	15524	14	
10	#12 SAE Zinc Washer	n/a	14	
11	3/4" Union Stainless Steel	07114	2	
12	3/4" x 1 1/2" Nipple Stainless Steel	07113	2	
13	3/4" Motorized Drain Valve Stainless Steel	09117	1*	
14	3/4" Ball Valve 316 Stainless Steel	09036	1	
15	3/4" Tee Stainless Steel	07115	1	
16	3/4" x 5" Nipple Stainless Steel	07011	2	
17	3/4" 90° Elbow Stainless Steel	07112	1	
18	Thermocouple Housing - Plain	16071	1*	
19	Type K Thermocouple	15853	1*	
20	DDR Float Plate Assembly	95009	1	
21	DDR Float Plate Gasket	05052	1	
22	10-32 x 3/4" Hex Bolt	15523	10	
23	1/2" LB Type Conduit Body	15079	1	
24	1/4" x 1/2" Hex Reducer	15694	1	
25	1/4" Coupling 304 SST	07001	1	
26	Low Water Float Switch	15048	1	
27	1/4" 90 Elbow 304 Stainless Steel	07002	1/2 *	
28	Water Fill Float Valve and Ball 316 Stainless Steel	09030	1	
29	1/2" Motorized Ball Valve Stainless Steel	09120	1*	
30	1/4" x 1 1/2" Nipple Stainless Steel	07043	2*	
31	1/4" Union Stainless Steel	07189	1*	
32	Overtemp Switch Housing	15072	3	
33	Overtemp Protection Switch	15047	1	
34	Heat Exchanger Gasket	05386	2	
35	Cover Gasket	15520	1	
36	Exhaust Over Temperature Switch 450°F Manual Reset	21022	2	
37	Overtemp Switch Plate	99170	2	
38	3" Hose Clamp	15606	2	
39	3/8-16 J-Nut	15850	6	
40	Burner Flange Gasket	05901	2	
41	Burner Flange	21072	2	
42	3/8-16 x 1 Hex Bolt	15943	6	
43	3/8 Stainless steel washer	15945	6	
44	Modulating Gas Fired Burner - See Burner Assembly Parts List	A	1	
45	On/Off Gas Fired Burner - See Burner Assembly Parts List	A	1	
46	Control Enclosure	12003	1	
47	Time Delay On Relay	12022	2	
48	Relay Base	12020	5	
49	2 amp Fuse	12063	1	
50	Fuse Holder	12085	2	
51	4 amp fuse	12065	1	
52	Step-Down Transformer	12245	1	
53	Finder Relay	12018	3	
54	4 Point Terminal Strip	12045	1	
55	INTAC [®] Microprocessor	12312	1	
56	7 Pin Terminal Connector	12310	4	
57	6 Pin Terminal Connector	12309	5	
58	Push Button Light with NC Relay	21021	2	

Notes/Codes:

A = Part Number and quantity vary with model number.

* Optional feature that may not be on all equipment.

When ordering replacement or spare parts please have Model and Serial numbers.

NEMA-12 HUMIDIFIER CONTROL CABINET
WITH DOOR OPEN

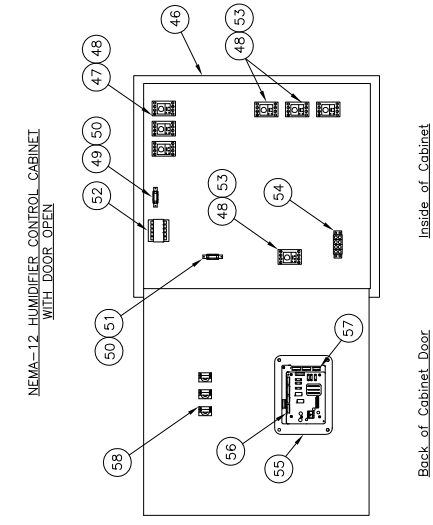

Inside of Cabinet
Back of Cabinet Door

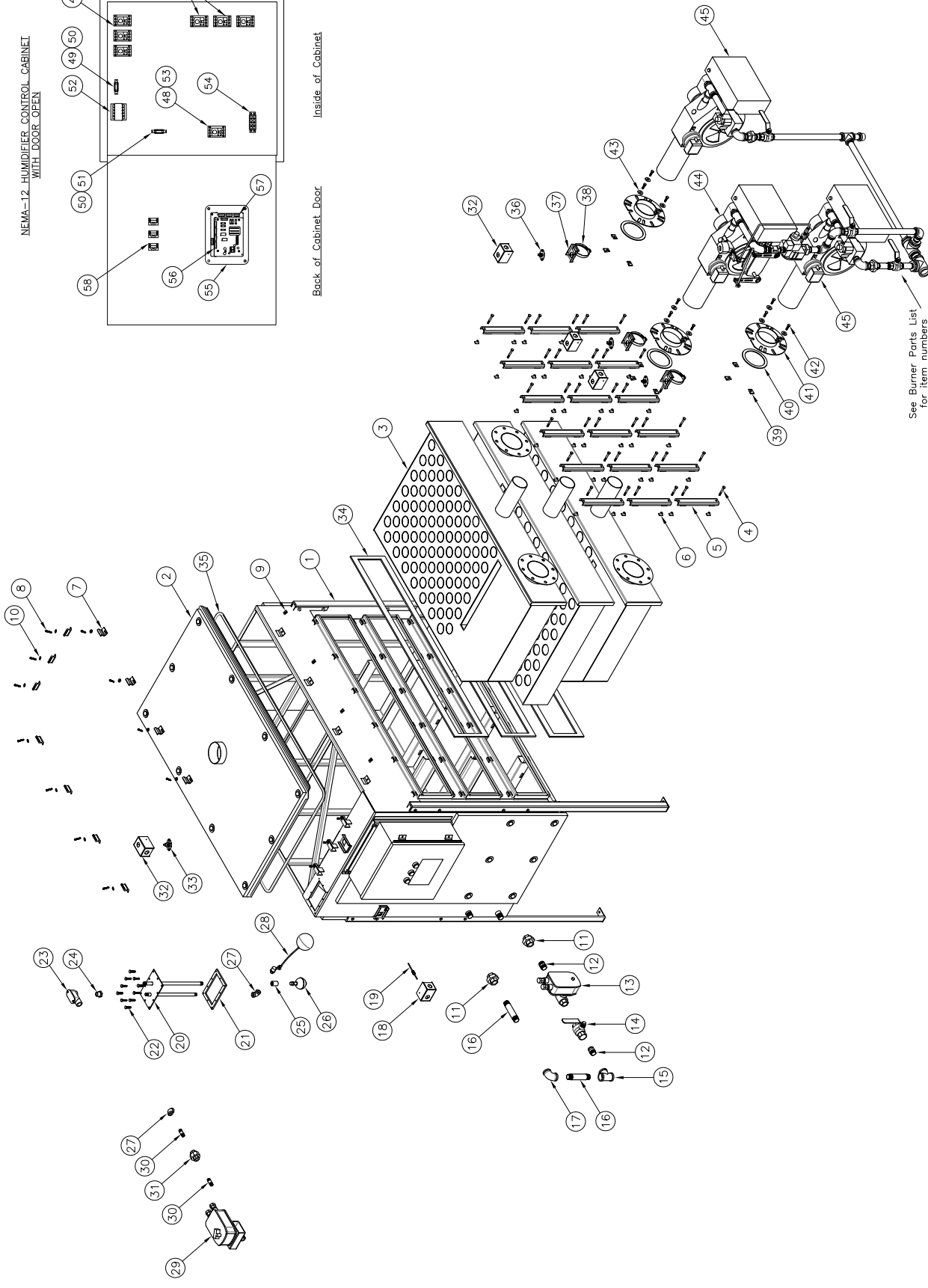

See Burner Parts List
for item numbers



Title: GXDDR-12 EXPLODED ASSEMBLY		
Scale: No Scale	Date: April 30, 2013	Drwn: S.A.M.
		Dwg No: GXDDR-12 EXPLODED ASSEMBLY

**PURE Humididfier Co. "GXDDR-12"
Parts List & Two Year Recommended Spare Parts**

Item No.	Description	Part No.	Qty Per Unit	Rec. SpareQty
1	GXDDR-12 Reservoir Assembly	10027	1	
2	GXDDR-12 Reservoir Cover Assembly	99087	1	
3	GX-4 Heat Exchanger Assembly	A	3	
4	U-Clamp Bolts 1/4-20 x 2 Zinc Hex	15841	36	
5	U-Clamp Bar Assembly	99136	18	
6	1/4"-20 Weld Nut	15702	36	
7	Cover Clamp	15930	14	
8	Cover Clamp Screws 10-24 Hex Socket	15522	14	
9	10-24 U-Nut	15524	14	
10	#12 SAE Zinc Washer	n/a	11	
11	3/4" Union Stainless Steel	07114	2	
12	3/4" x 1 1/2" Close Nipple Stainless Steel	07113	2	
13	3/4" Stainless Steel Motorized Drain Valve	09117	1*	
14	3/4" Ball Valve 316 Stainless Steel	09036	1	
15	3/4" Tee Stainless Steel	07115	1	
16	3/4" x 5" Nipple Stainless Steel	07011	2	
17	3/4" 90° Elbow Stainless Steel	07112	1	
18	Thermocouple Housing - Plain	16071	1*	
19	Type K Thermocouple	15853	1*	
20	DDR Float Plate Assembly	95009	1	
21	DDR Float Plate Gasket	05052	1	
22	10-32 x 3/4" Hex Bolt	15523	10	
23	1/2" Type LB Conduit Box	15079	1	
24	1/4" x 1/2" Hex Reducer	15694	1	
25	1/4" Coupling 304 Stainless Steel	07001	1	
26	Low Water Float Switch	15048	1	
27	1/4" 90° Elbow 304 Stainless Steel	07002	1/2 *	
28	Water Fill Float Valve and Ball 316 Stainless Steel	09030	1	
29	1/2" Motorized Stainless Steel Ball Valve	09120	1*	
30	1/4" x 1 1/2" Nipple Stainless Steel	07043	2*	
31	1/4" Union Stainless Steel	07189	1*	
32	Overtemp Switch Housing	15072	4	
33	Overtemp Protection Switch	15047	1	
34	Heat Exchanger Gasket	05386	3	
35	Cover Gasket	15520	1	
36	Exhaust Over Temperature Switch 450°F Manual Reset	21022	3	
37	Overtemp Switch Plate	99170	3	
38	3" Hose Clamp	15606	3	
39	3/8-16 J-Nut	15850	9	
40	Burner Flange Gasket	05901	3	
41	Burner Flange	21072	3	
42	3/8-16 x 1 Hex Bolt	15943	9	
43	3/8 Stainless steel washer	15945	9	
44	Modulating Gas Fired Burner - See Burner Assembly Parts List	A	1	
45	On/Off Gas Fired Burner - See Burner Assembly Parts List	A	2	
46	Control Enclosure	12003	1	
47	Time Delay On Relay	12022	3	
48	Relay Base	12020	7	
49	2 amp Fuse	12063	1	
50	Fuse Holder	12085	2	
51	4 amp fuse	12065	1	
52	Step-Down Transformer	12245	1	
53	Finder Relay	12018	4	
54	4 Point Terminal Strip	12045	1	
55	INTAC [®] Microprocessor	12312	1	
56	7 Pin Terminal Connector	12310	4	
57	6 Pin Terminal Connector	12309	5	
58	Push Button Light with NC Relay	21021	3	

Notes/Codes:

A = Part Number and quantity vary with model number.

* Optional feature that may not be on all equipment.

When ordering replacement or spare parts please have Model and Serial numbers.

BURNER PARTS LIST X4

1	Burner Housing	24	Pilot Tubing
2	Inlet Ring	25	Pilot Assembly
3	Blast tube (6", 9", 12")	26	Ignition Electrode
4	Gun Assembly	27	Flame Rod
5	Flange Gasket	28	Back Plate
6	Mounting Flange	29	Inner Damper
7	Blower Wheel	30	Middle Damper
8	Motor Plate	31	Outer Damper
9	Blower Motor	32	Air Sensing Tube
10	Air Switch	33	Orifice Kit
11	24 Volt Transformer	34	Direct Spark Transformer
12	Panel & Door	35	Gas Piping Support Bracket
13	Flame Monitor	36	Damper Axle
14	Grounding Lug	37	Relay
15	Nipple Tapped	38	5/16" Ball Joint Swivel
16	Gun Head	39	Mod Motor
17	Side Orifice tee	40	Butterfly Valve
18	Side Orifice Spring	41	5/16" Linkage Rod
19	Pilot Regulator	42	Light
20	Pilot Solenoid Valve	43	Axle Bushing
21	Combination Gas Valve	44	1/2" Damper Arm
22	Main Gas Cock	45	Pie DPR Retainer Washers
23	Pilot Gas Cock		

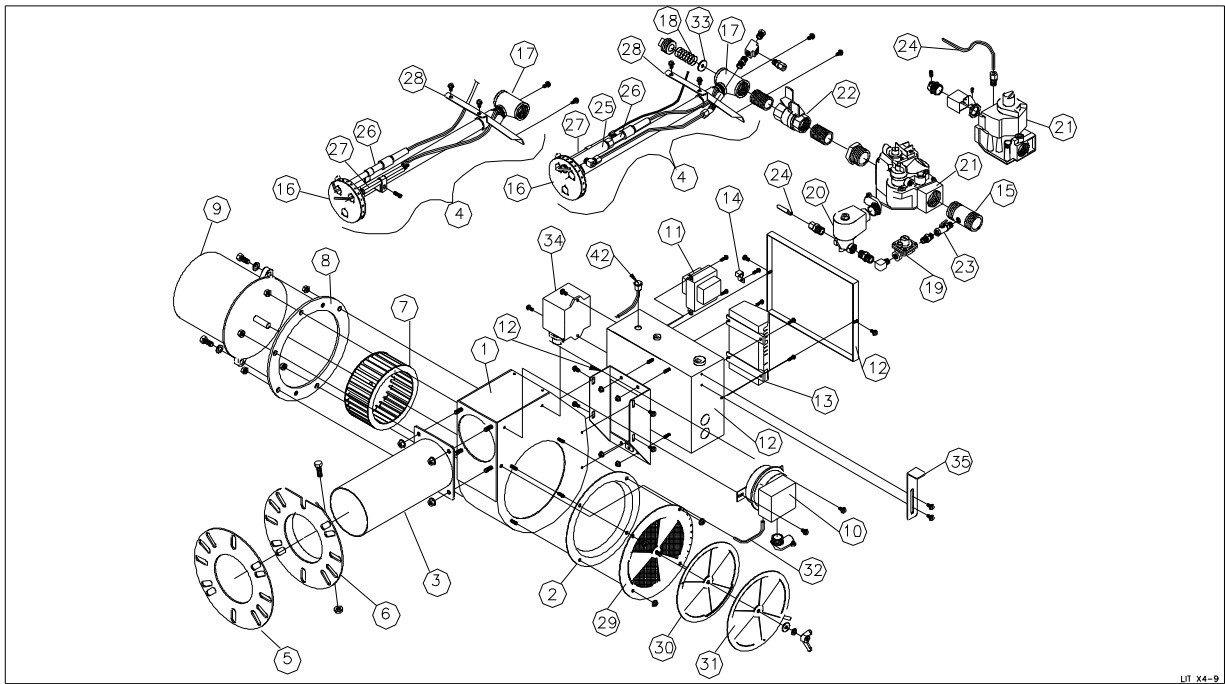

LIT X4-9
REV0 12/01/03

Figure 10: X4 general assembly and parts

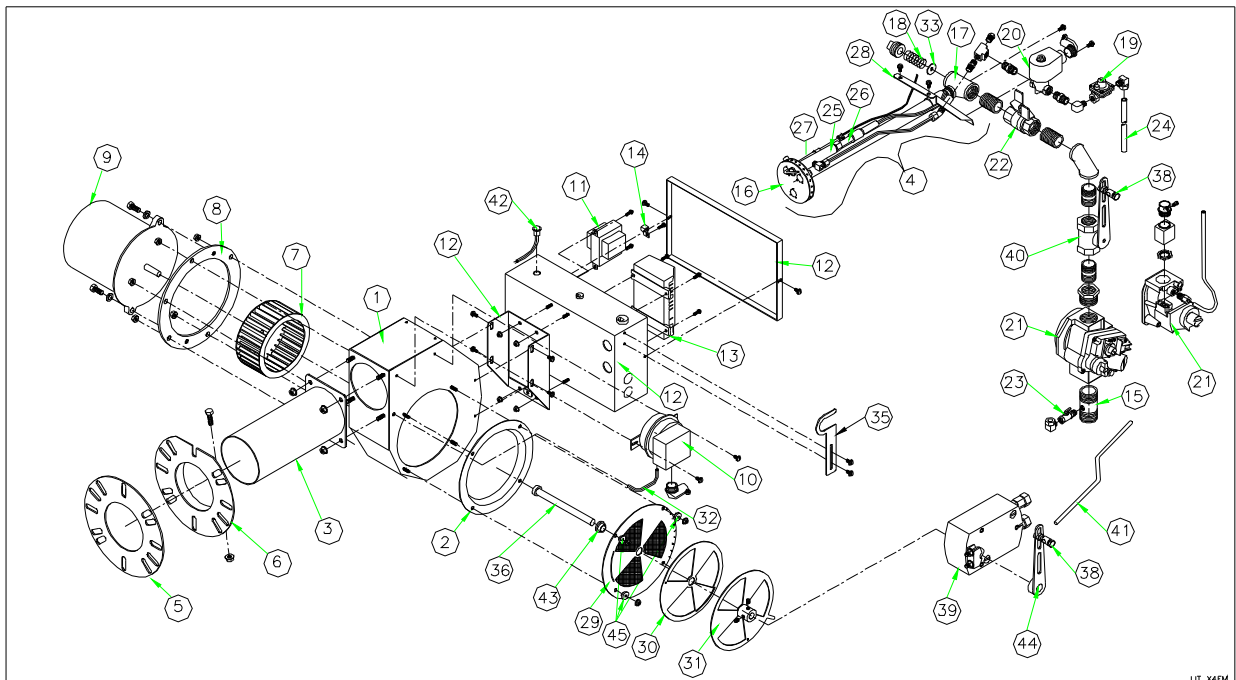

LIT X4FM
REV0 12/01/03

Figure 11: X4M general assembly and parts

DISCLAIMER

Product Changes: Changes in products may be required from time to time due to the need for continuing improvement of products and due to factors beyond PURE Humidifier Co.'s control. PURE Humidifier Co. reserves the right to make reasonable changes in products, specifications and performance of any kind without notice or liability. PURE Humidifier Co. also reserves the right to deliver revised designs or models of products against any order, unless this right is specifically waived in writing by PURE Humidifier Co. PURE Humidifier Co. shall have no responsibility whatsoever with respect to changes made by the manufacturer in products sold but not manufactured by PURE Humidifier Co.



141 Jonathan Blvd. North
Chaska, MN 55318
Tel: (952) 368-9335 Fax: (952) 368-9338
www.purehumidifier.com